

THREE SPRINGS DESIGN GUIDELINES

MASTER DEVELOPMENT SIGNAGE PROGRAM

FINAL: DECEMBER 3, 2012



1.0 SIGNAGE OVERVIEW	1
1.1 THREE SPRINGS LOGOS	3
1.2 IDENTITY COLLATERAL COLORS	3
1.3 PRIMARY SIGNAGE TYPOGRAPHY	4
1.4 SECONDARY SIGNAGE TYPOGRAPHY	4
2.0 PERMANENT SIGNAGE	5
2.1 ENTRY MONUMENT SIGNAGE	5
2.2 NEIGHBORHOOD DISTRICT MAP	5
2.3 NEIGHBORHOOD DISTRICT ICONS	6
2.4 NEIGHBORHOOD MARKERS	7
2.5 TRAIL ICON AND TRAIL MONUMENT SIGNAGE	8
2.6 STREET SIGNAGE	9
2.7 DIRECTIONAL SIGNAGE	10
2.7.1 ENTRY AVENUE A ROAD TYPE	
2.7.2 ENTRY AVENUE B, URBAN STREETS A,B,C	
2.8 LIGHTING AND STOP SIGNS	12
2.9 CIVIC PLAZA BANNERS WITH BACK IN PARKING SIGNAGE	13
2.10 ROUNDABOUT SIGNAGE	14
2.11 INTERPRETIVE TRAIL SIGNAGE	15
2.12 PEDESTRIAN UNDERPASS SIGNAGE	16
2.13 PEDESTRIAN UNDERPASS TYPOGRAPHY	16
3.0 SHORT TERM/TEMPORARY SIGNAGE	17
3.1 COMMUNITY IDENTIFICATION SIGNS	18
3.1.1 PRIMARY COMMUNITY IDENTIFICATION ENTRY AVENUE A ROAD TYPE	
3.1.2 SECONDARY COMMUNITY IDENTIFICATION ENTRY AVENUE A AND B ROAD TYPE	
3.2 EVENT RELATED DIRECTIONAL SIGNS	20
3.3 KIOSK	21
3.3.1 PRIMARY KIOSK	
3.3.2 SECONDARY KIOSK	
3.4 FUTURE SITE IDENTIFICATION	23
3.5 CONSTRUCTION IDENTIFICATION	24
3.6 SITE ORIENTATION	25
3.7 MIXED-USE PAD SITES	26

3.8 RESIDENTIAL BUILDER	27
3.9 RESIDENTIAL FOR SALE	28
3.9.1 REAL ESTATE AGENCY/HOMEBUILDER	
3.9.2 RESIDENTIAL FOR SALE - BY OWNER	
3.10 MAIN SALES CENTER	29
3.11 EXISTING MODEL HOME	30
3.12 SALES TRAILER	31
3.13 SANDWICH BOARDS	32
3.14 ORNAMENTAL SIGNAGE	33
3.15 ENTRANCE FLAGS	33
3.16 FEATHERED FLAGS	34
3.17 BANNERS	35
3.17.1 ENTRY ROAD	
3.17.2 DISTRICT	
3.17.3 MIXED-USE STREET	

1.0 SIGNAGE OVERVIEW

The Master Signage Program offers a coordinated sign program to provide visual and harmonious signage elements for Three Springs. The program strives to provide a balance between vitality and flexibility in the various stages of development at Three Springs.

The intent of the criteria in the Master Signage Program is to ensure that the signage within Three Springs will contribute to the intent of the project as a whole and to create a vibrant atmosphere with clear, functional information for the wayfinding systems and the identification of venues and establishments. The Program defines a wide range of elements for 1) temporary, 2) permanent. The general sign criteria are not intended to be prescriptive in nature, but rather to provide guidelines for a cohesive signage program with flexibility for sign type and design options.

Refer to Three Springs Design Guidelines, 4.9 Signage for signage within mixed use and special districts.

Guidelines

The intent of the Master Sign Program is to provide a consistent identity and effective and accessible information displays under the following guidelines:

1) Placement

- a. Sign placement should be strategically located so as not to compete with other signs or elements in the landscape.
- b. Sign placement should allow for adequate decision-making time and ability to be seen with the vertical and horizontal viewing ranges of the average person.

2) Messaging

- a. Sign messaging should convey a clear, uncomplicated, and logical message(s) with short lines of information recognizing that travelers at 25-45 mph per hour are typically only able to read effectively three messages or three lines of information
- b. Sign messaging should consider universally accepted symbols and pictographs as alternatives to wording where possible.

3) Coherence/Legibility

- a. Sign coherence should be designed to factor for effective reading/viewing times.
- b. Sign design should address legibility and letter height as recommended by the Society of Environmental Graphic Design (SEGD).
- c. Sign legibility should consider lighter colored lettering on darker backgrounds for better contrast and legibility both day and night.
- d. Interchangeable drop down sign panels should consider contrast with the land background for all seasons. In some instances, two color panels may be needed to correspond with the changing background vegetation.

4) Illumination

- a. Sign illumination should be consistent with the City of Durango Outdoor Lighting Ordinance. The sign illumination shall focus downward on the sign without any light spillage onto thoroughfares. The sign illumination light should be concealed from view and of an appropriate character that is consistent with the Three Springs Neighborhood.
- b. Internally illuminated or neon signs are not permitted.
- c. Strip lighting atop a sign, preferably solar powered, is encouraged.

5) Sign Maintenance

- a. Sign shall be maintained to the highest standards.
- b. Maintenance activities shall include but are not limited to regular cleaning, replacement of type and/or images, and touch-up paint.
- c. Signs that have been broken, damaged, or maliciously removed shall be repaired or replaced in a timely manner.
- d. Signs no longer needed shall be removed.

Standards

The Master Signage Program illustrates the established criteria for an overall graphic representation of Three Springs including logo, palette of colors, typography (primary and secondary), neighborhood icons, and street signs as defined by the Master Developer. These elements together help to promote recognition of Three Springs with a look of quality and attention to detail and should be included in wayfinding, identity and information/collateral forms (generally presented by the Master Developer). Additional icons may be added with the addition of new neighborhoods/districts or activity names as needed.

In some instances, the Master Signage Program requires use of a specific template (designed by the Master Developer) to include the designated criteria. Permission shall be obtained from the Master Developer for use of the Three Springs logo and typography in all signage applications.

All on-site signage shall conform to the Three Springs standards for signs and shall be reviewed and approved by the DRC.

Multi-family entry monument signage shall be limited to primary and secondary access points.

The Three Springs Specific Standards are included on the following pages.

Prohibited Signs

The following signs shall not be permitted unless approved by Special Permission of the DRC after review of a site-specific plan:

- 1) Portable signs, such as freestanding or wheeled signs higher than 48" in height
- 2) Signs which incorporate any flashing, moving, or intermittent lighting
- 3) Rotating or animated signs or signs which contain any moving parts (excluding flags or banners)
- 4) Signs which are erected or constructed to any part of the roof

1.1 THREE SPRINGS LOGOS



PMS 3025
100c, 0m, 0y, 51k
003366 - 0r 51g 102b



PMS 131 C
0c, 27m, 100y, 8k
CC9900 - 204r 153g 0b



The logo can be represented in black and white or a screen of black (0y, 0m, 0y, 22k):

1.2 IDENTITY COLLATERAL COLORS



PMS 329
100c, 0m, 47y, 47k
006666 - 0r 102g 102b



PMS 7459
60c, 0m, 0y, 15k
3399CC - 51r, 153g, 204b



PMS 4715
0c, 38m, 43y, 34k
996666 - 153r 102g 102b



PMS 2622
70c, 100m, 0y, 40k
663366 - 102r 51g 102b



PMS 583
27c, 0m, 100y, 15k
99CC00 - 153r 204g 0b



PMS 5825
0c, 0m, 87y, 60k
666633 - 102r 102g 51b

The marketing collateral color palette is a group of colors that work well with the Three Springs Identity. These colors can be used in the design of identity pieces for design elements, backgrounds, and typography to accent the logo colors.

1.3 PRIMARY SIGNAGE TYPOGRAPHY

Myriad

AaBbCcDdEeFfGgHhIiJjKkLlMmNn
OoPpQqRrSsTtUuVvWwXxYyZz
1234567890

Myriad Bold

AaBbCcDdEeFfGgHhIiJjKkLlMmNn
OoPpQqRrSsTtUuVvWwXxYyZz
1234567890

Myriad Italic

AaBbCcDdEeFfGgHhIiJjKkLlMmNn
OoPpQqRrSsTtUuVvWwXxYyZz
1234567890

Myriad Condensed Bold

AaBbCcDdEeFfGgHhIiJjKkLlMmNn
OoPpQqRrSsTtUuVvWwXxYyZz
1234567890

Primary Signage Font: Myriad

The primary signage font is Myriad. It is a family of fonts that works well with Three Springs primary font families. Myriad Condensed, Regular, Condensed Bold and Condensed Italic are specified and are recommended for a variety of applications including all fonts for development and district signage.

1.4 SECONDARY SIGNAGE TYPOGRAPHY

Officina Sans Book

AaBbCcDdEeFfGgHhIiJjKkLlMmNn
OoPpQqRrSsTtUuVvWwXxYyZz
1234567890

Officina Sans Bold

AaBbCcDdEeFfGgHhIiJjKkLlMmNn
OoPpQqRrSsTtUuVvWwXxYyZz
1234567890

Officina Sans Book Italic

AaBbCcDdEeFfGgHhIiJjKkLlMmNn
OoPpQqRrSsTtUuVvWwXxYyZz
1234567890

Secondary Signage Font: Officina Sans

(used only on the roundabout signage or similar government regulated signage)

The Officina Sans type family is the secondary system type style and is used in creating the Roundabout Signage to comply with the regulatory state signage. Type style consistency is one of the basin components that contribute to the identifiable Three Springs design style. Officina Sans Regular, Bold and Italic are specified or recommended for any signage that is regulated by the government.

2.0 PERMANENT SIGNAGE

2.1 ENTRY MONUMENT SIGNAGE



Three Spring Entry Monument

2.2 NEIGHBORHOOD DISTRICT MAP

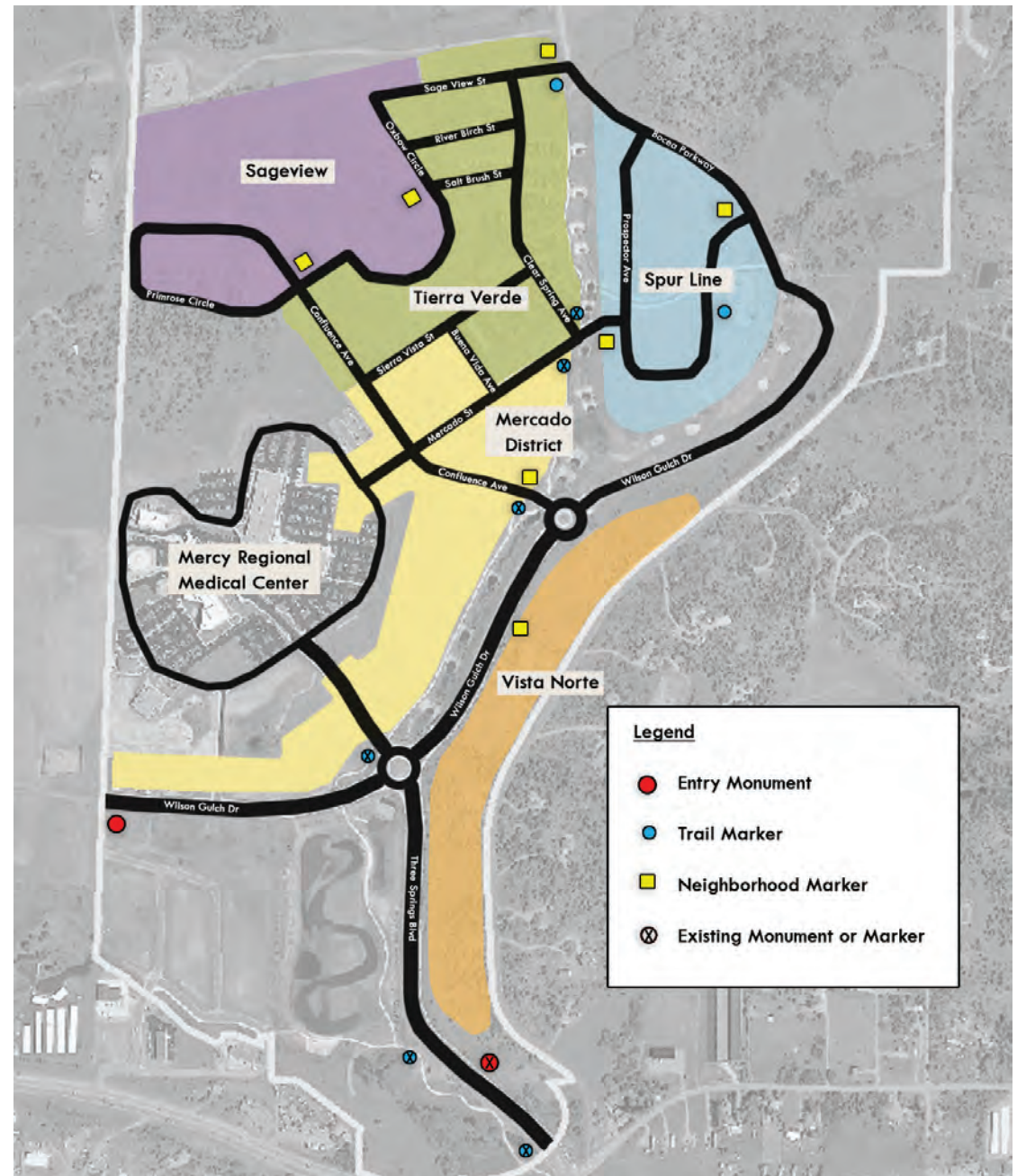

2.3 NEIGHBORHOOD DISTRICT ICONS



Vista Norte

PMS 7459
PMS 329



Mercado District

PMS 7459
PMS 131



Tierra Verde

PMS 2622
PMS 583



Spur Line

PMS 131
PMS 2622



SageView

PMS 329
PMS 583



Trail Icon



SUIT logo

Neighborhood icons are made of powder coated cut metal(aluminum). Each icon is manufactured in two separate pieces.

2.4 NEIGHBORHOOD MARKERS

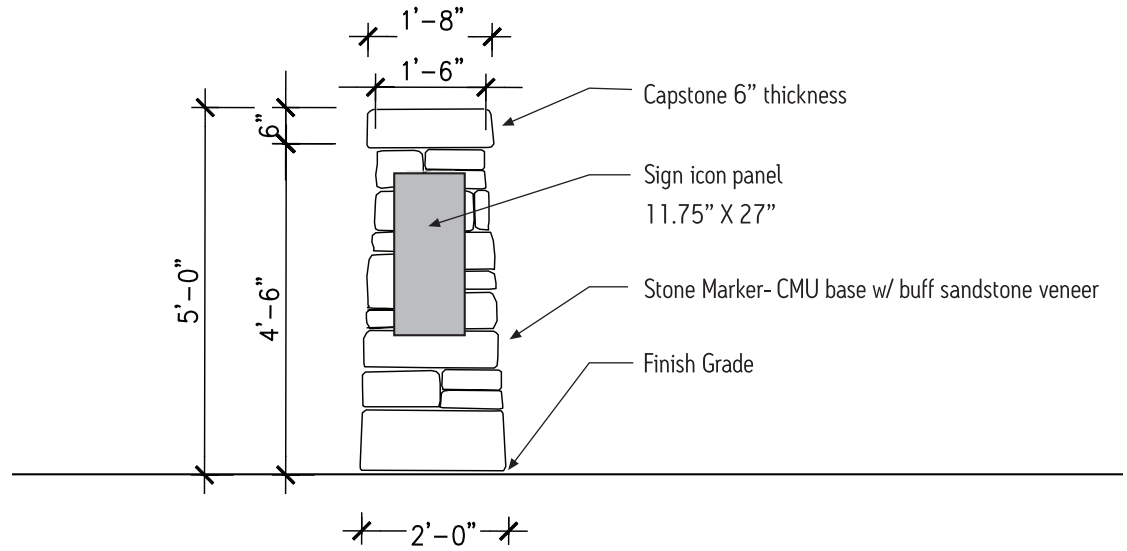
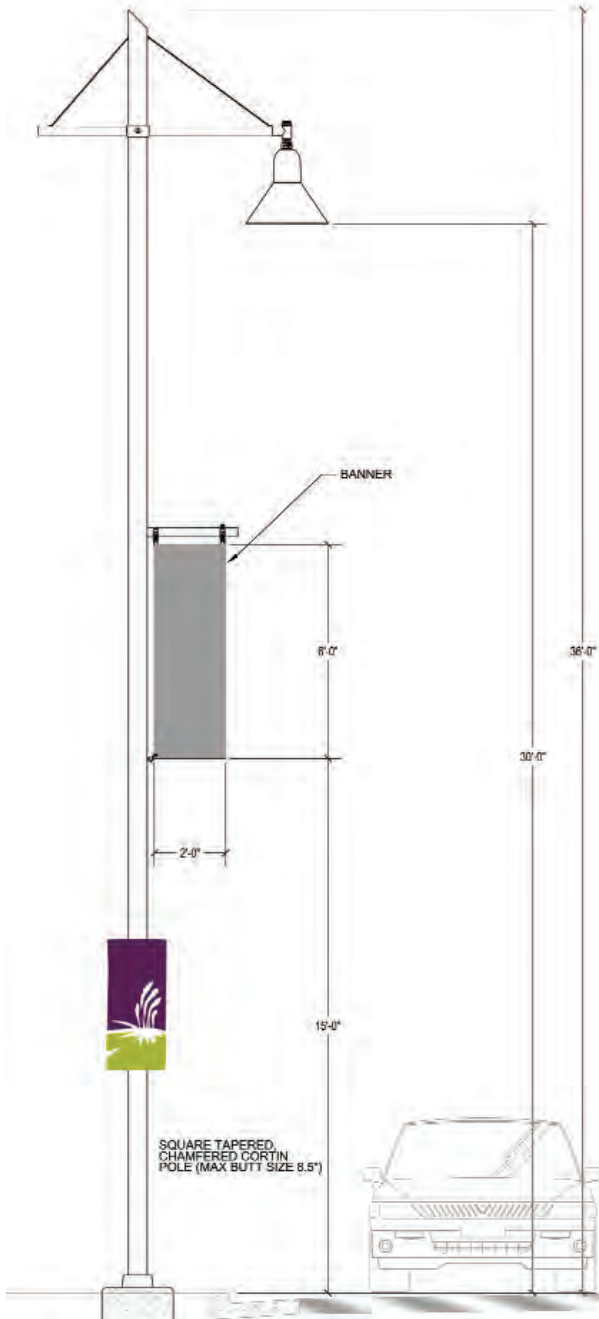

2.5 TRAIL ICON AND TRAIL MONUMENT SIGNAGE

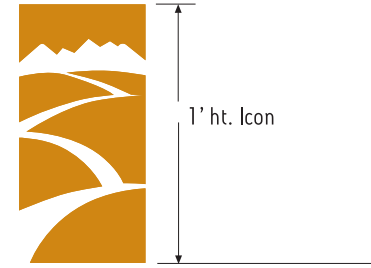

Trail typography
2.5" cap type height
centered

Florida
Canal Trail

] 3"Space
] 2.5" cap height
] 1.25" leading space

Trail Icon

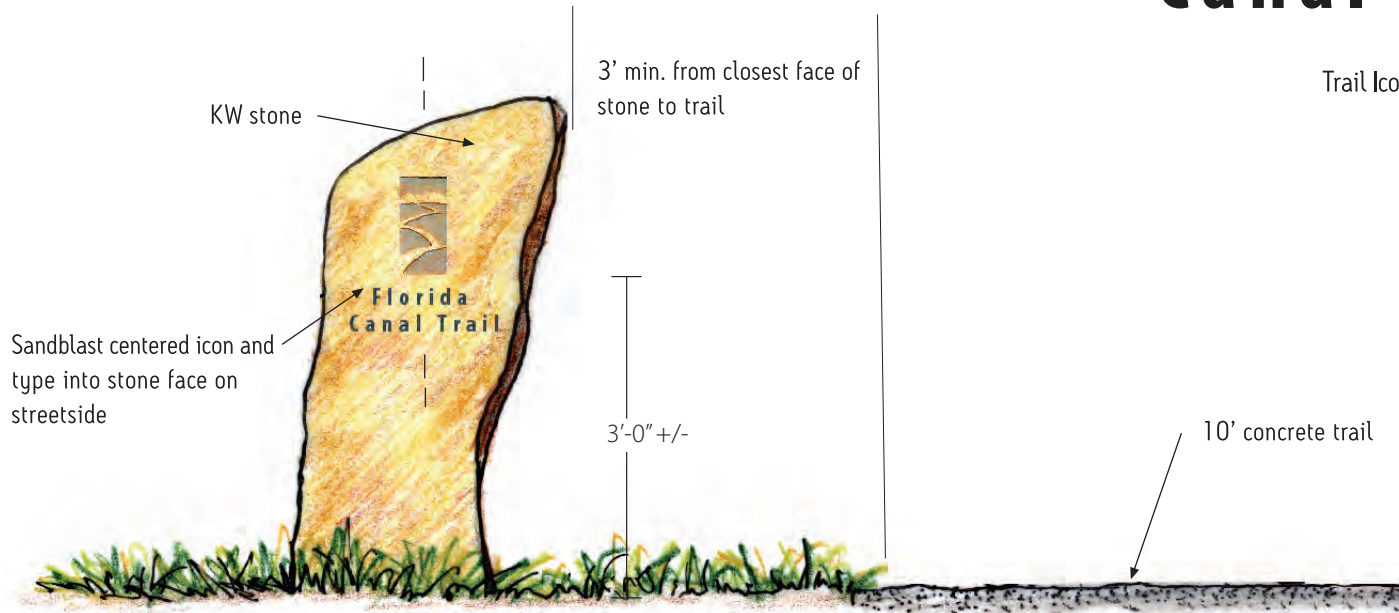

Trails:
Confluence Trail
East-West Trail
Florida Canal Trail
SMART 160 Trail

Trail marker will be of KW stone and have the Three Springs Icon sand blasted into the rock at a 80° angle. No rectangle or other image should be around the Icon.

2.6 STREET SIGNAGE

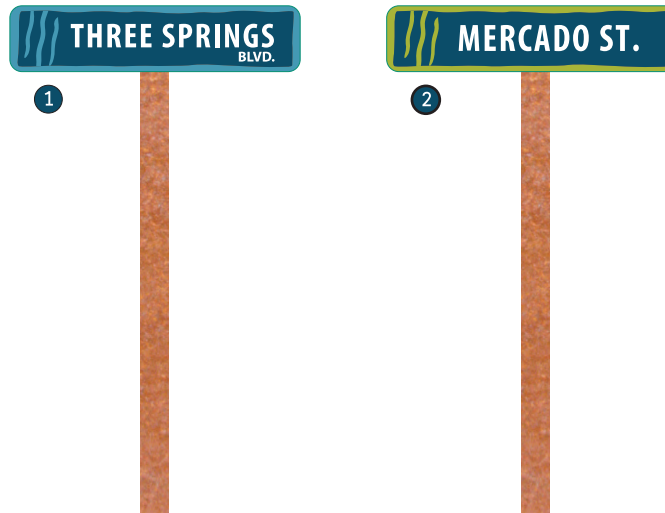

Powder painted sign with white reflective vinyl letters and bold border and icon applied

Type: Myriad condensed bold, caps/lower case

Size: 3" letters height
7" sign height

Background:

Powdered painted Pantone 3025 (blue-gray sign ground) with white reflective letters

Secondary color options for icon and border depending on neighborhood district:

- ① Pantone 5459 (light blue)
- ② Pantone 583 (lime green)
- ③ Pantone 329 (dark green)
- ④ Pantone 131 (ochre yellow)
- ⑤ Pantone 2622 (purple)

2.7 DIRECTIONAL SIGNAGE

Directional signs guide travelers (drivers/pedestrians) to specific destinations through information gateways. Temporary directional signs primarily include event or time-specific signs positioned to direct traffic to a particular location. The signs enable travelers to reach a desired destination through sound decisions made prior to and after critical junctures.

2.7.1 ENTRY AVENUE A ROAD TYPE

Roadway directional signs to guide traffic to the Mercado District and the Three Springs Information and Home Sales Center.

- Single faced aluminum sign
- Sign face maximum size 42" height x 56" width
- Maximum two (2) additional drop-down message parcels allowed and shall not exceed 11" height x 46" width
- Weathered steel frame and poles
- Ground clearance 5'6" at longest leg/toe of slope



2.7.2 ENTRY AVENUE B, URBAN STREETS A,B,C

Directional signs to guide traffic within a district/neighborhood.

- Single-faced aluminum sign with powder coated paint
- Sign face maximum size 55" height x 72" width
- Maximum six (6) removable panels (6.5" height x 46" wide) with 3" reflective vinyl lettering
- District icon to be 42" height x 16" wide
- Weathered steel 4" square pole frame with 9" top with rounded corners
- Logo to be 6" x 34" powder coated steel (match Three Springs Specific Standards)
- Ground clearance to be 28" height

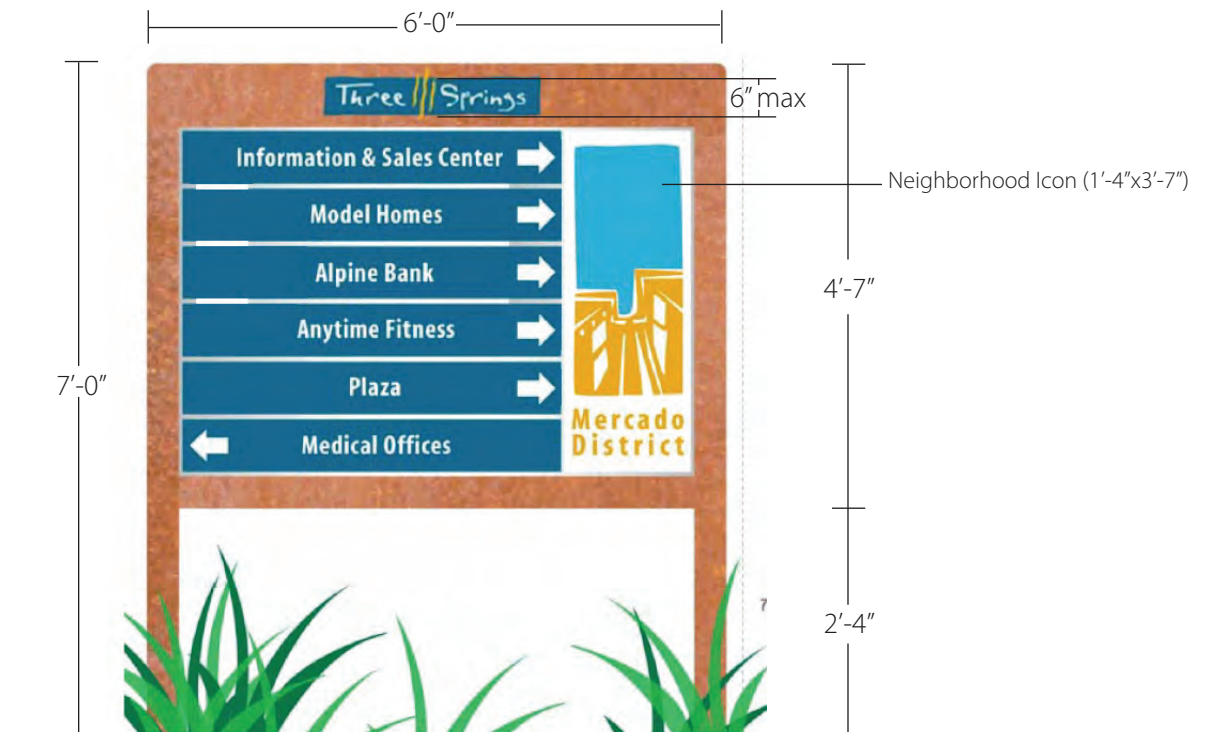

2.8 LIGHTING AND STOP SIGNS

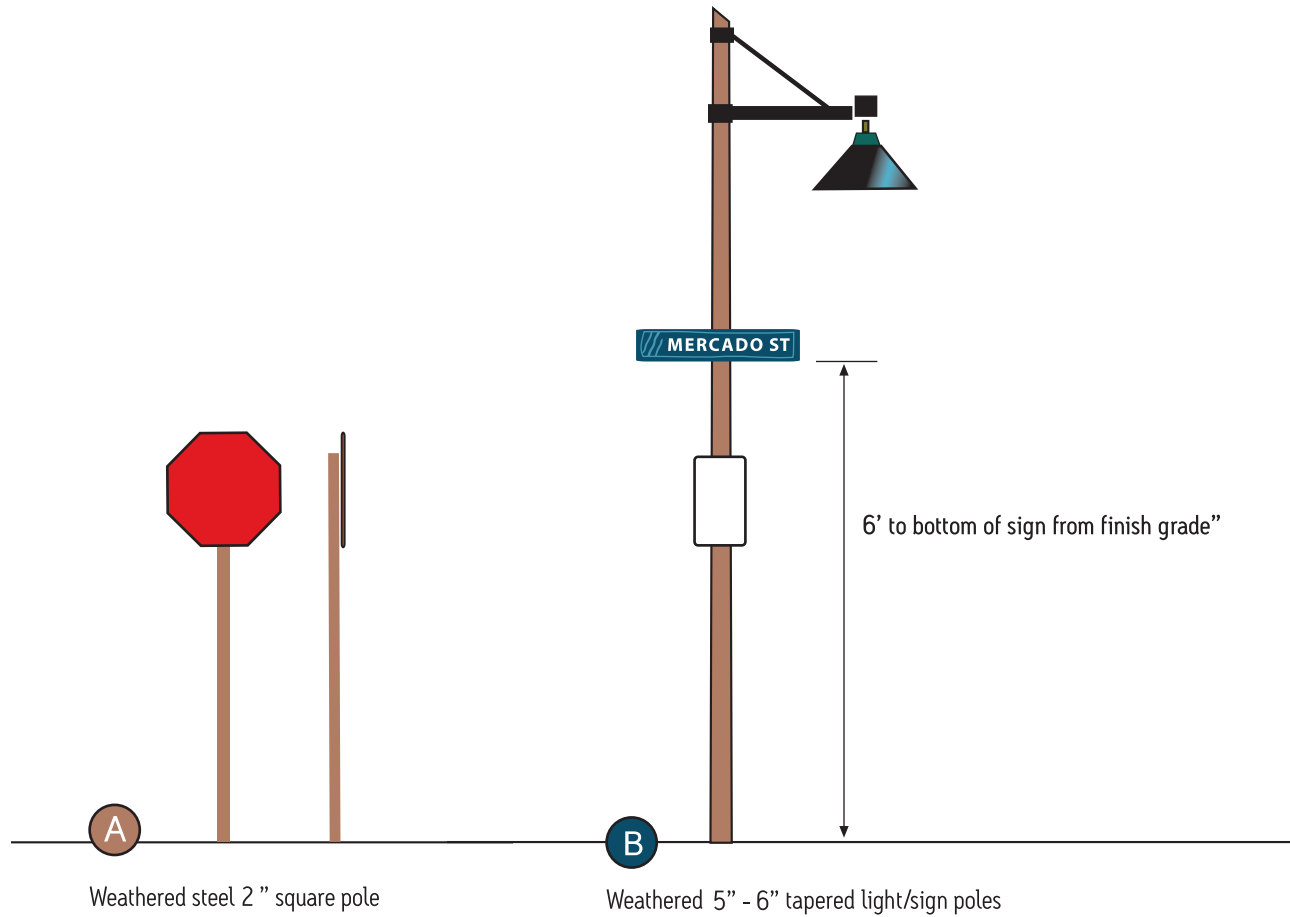

2.9 CIVIC PLAZA BANNERS WITH BACK-IN PARKING SIGNAGE

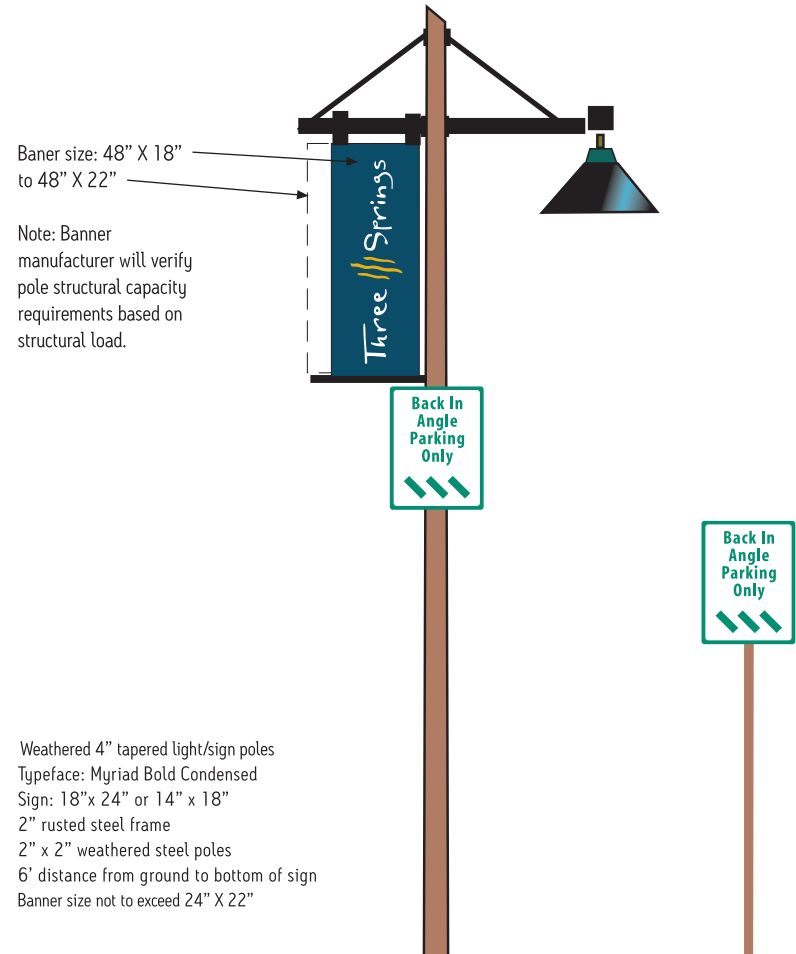
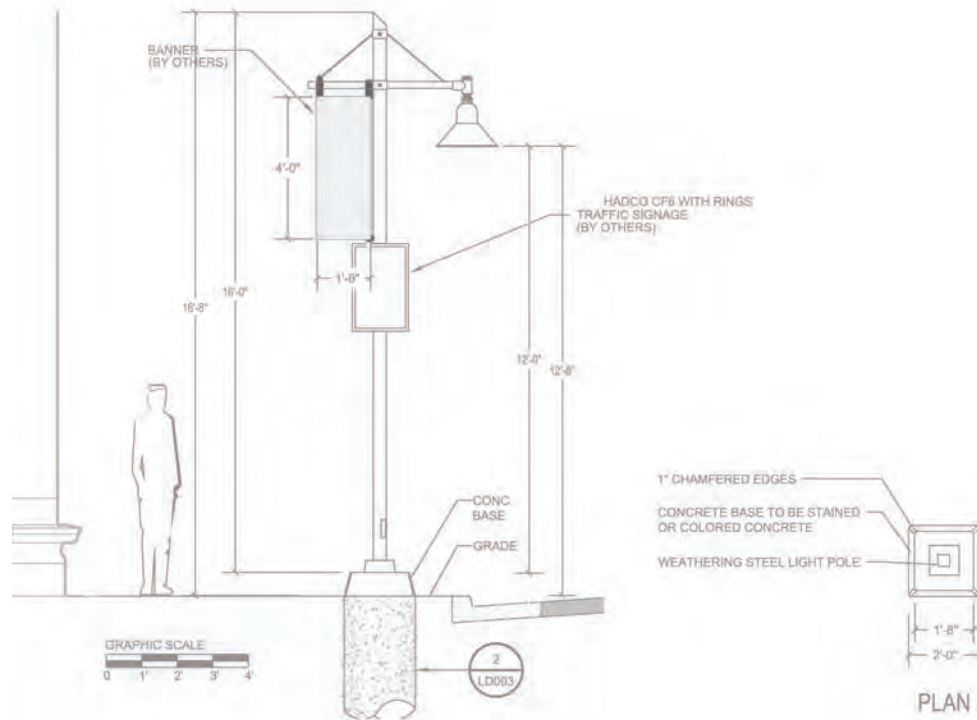

2.10 ROUNDABOUT SIGNAGE

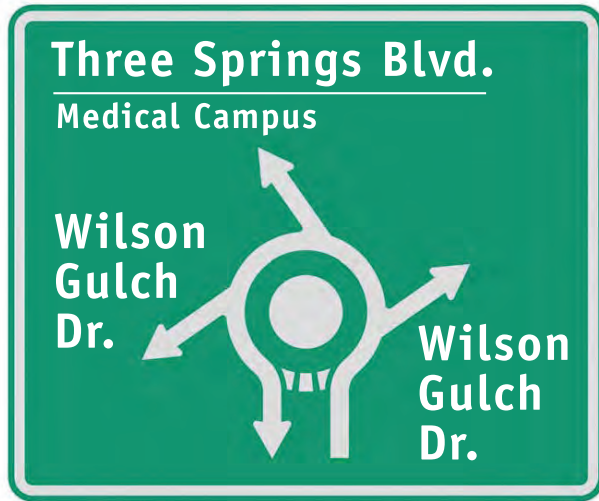

Typeface:
ITC Officina Sans Bold

Spacing on all text:
4% em space additional

Size - 60" x 60":
Main text - 380 pts.
14 pt. line
Smaller text - 313 pts.

Size - 60" x 72":
Main text - 435 pts.
Line: 17 pt.
Smaller text - 294 pts.

Roundabout 1 Signs 60" x 72"
Roundabout 2 Signs - 60" x 60"
1" rusted steel frame, 2- 3" rusted steel supports

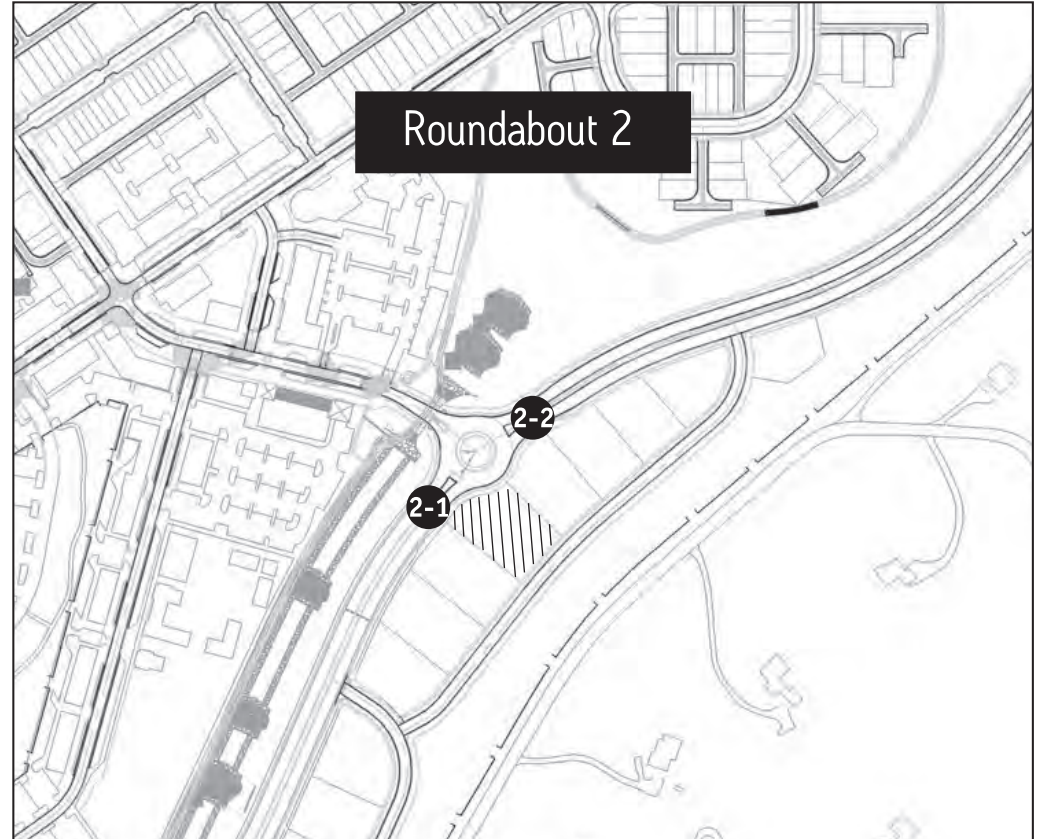

Roundabout 2 - 1



Roundabout 2 - 2

2.11 INTERPRETIVE TRAIL SIGNAGE

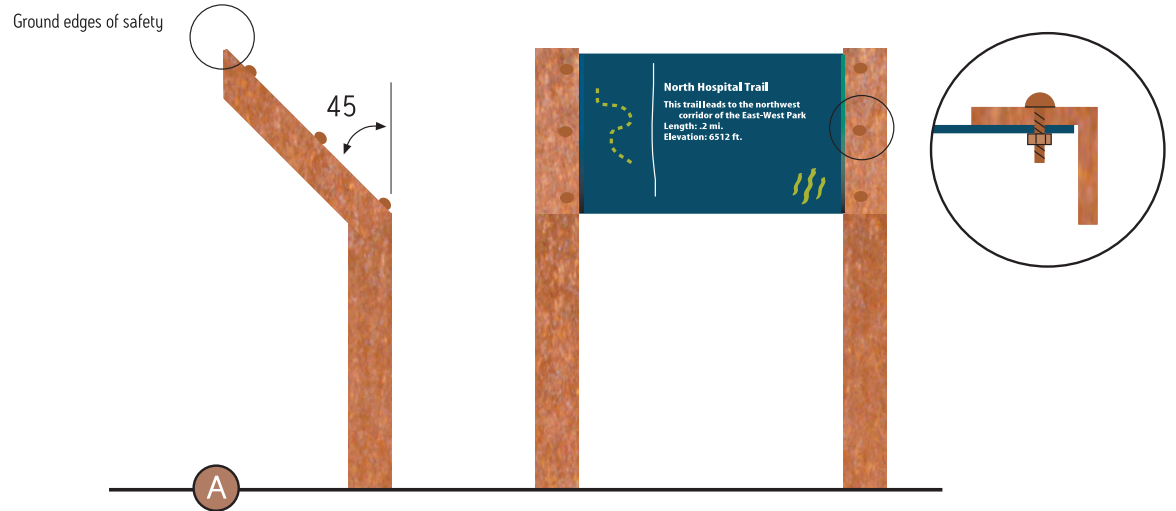

Core-ten 4" "L" rusted finish legs and face plate.
 Typography is Myriad Bold Condensed etched and painted white enamel on 1/4" core-ten.
 Background is Pantone 3025, border and icon are Pantone 583.

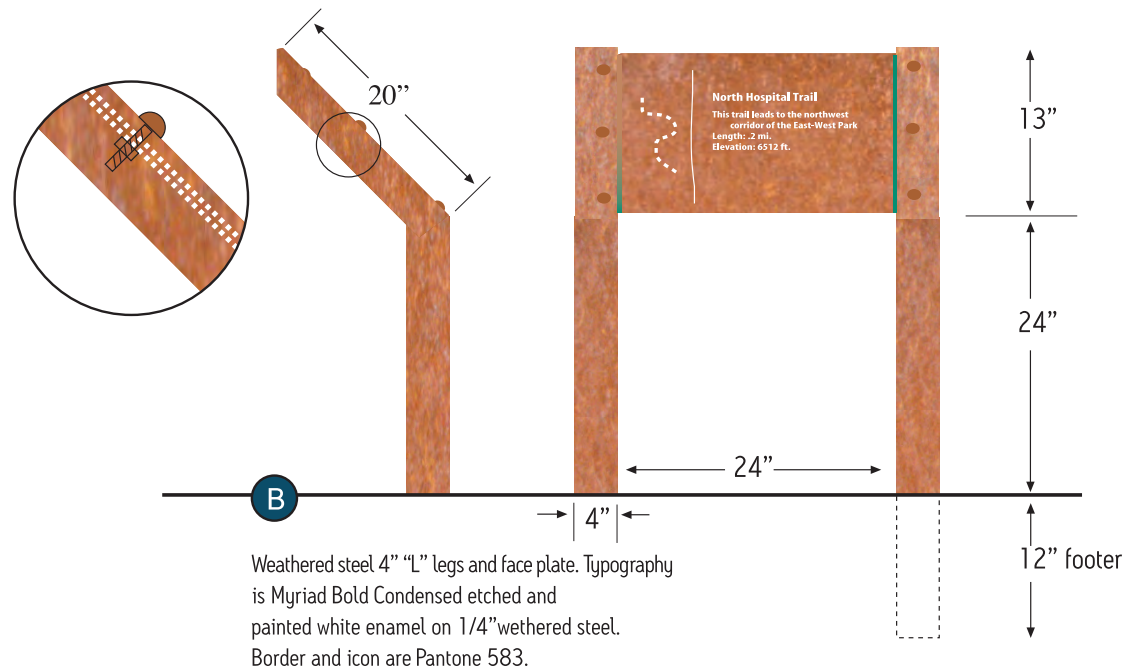

Weathered steel 4" "L" legs and face plate. Typography is Myriad Bold Condensed etched and painted white enamel on 1/4" wethered steel.
 Border and icon are Pantone 583.

2.12 PEDESTRIAN UNDERPASS SIGNAGE



The typeface we are using for Pedestrian Underpass Sandblasting is Myriad Condensed Bold with +2% em of letterspace. Upper and lower case letters and centered underpass inset area.

2.13 PEDESTRIAN UNDERPASS TYPOGRAPHY

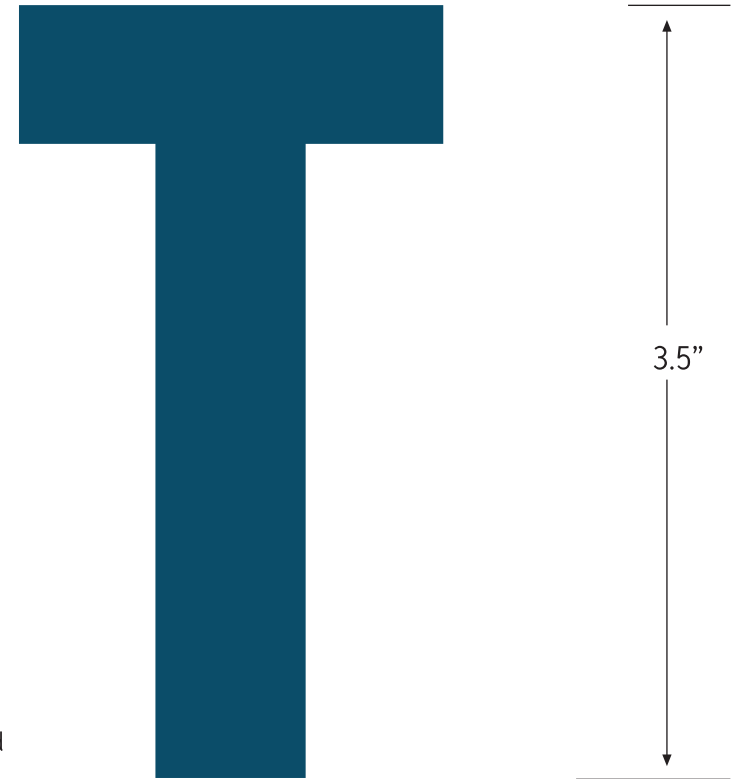

3.0 SHORT TERM/TEMPORARY SIGNAGE

The short term or temporary signage criteria provides for a wide-range of signage applicable to the construction phases of the development. Visitors to Three Springs during these stages of the development require visual information clarity to define the key information corridors in order to reach a specific destination.

For purposes of this document, the following definitions apply:

Short Term/Temporary Signage means certain signage needed in place during the build-out years including announcements, declarations, demonstrations, displays, illumination, insignia, surface or space when erected or maintained in view of the general public for identification, wayfinding, advertisement or promotion of interests, and safety of Three Springs including a business or an event. Temporary signage is generally free standing and not attached to a building.

Sign Area means the entire area within the outside border of a sign face per side face.

Applicability

The Short Term/Temporary Signage Program criteria apply to all temporary signage. In general, the majority of temporary signage will be proposed by the Master Developer. This Program describes the overall hierarchy of signs by type. Additional case-by-case proposals will be anticipated through subsequent development of Village I. Review and approval of all on-site temporary signage is required by the Three Springs Design Review Committee (DRC).

Location

Temporary signs should be generally located on private property (individual lots or parcels) unless approved by the City of Durango - Public Works for right of way locations.

Material Types

Materials and treatments for the sign face and mountings may consist of the following options:

Sign Face Material

- a. Wallboard, plastic or other light weight, durable material
- b. Light weight metal sheet

Posts

- a. Wood posts shall be rough sawn and stained with Minwax Sedona Red 222-low VOC or preservative treated wood in brown tone or approved equal.
- b. Steel posts may be weathered or Core-Ten steel with sealant. Recycled or reclaimed steel may be acceptable.

Landscaping/Monumentation

- a. Free standing signs located on the overlot graded areas may implement landscaping and rock monumentation, if desired.
- b. If signs are located in an area with access to irrigation the area around the base of the sign should include planting of shrubs and perennials. The height of the plants should be lower than the bottom of the sign.

3.1 COMMUNITY IDENTIFICATION SIGNS

These signs identify the Three Springs community and entry to districts, neighborhoods, places of business, and public facilities including the Mercy Regional Medical Center campus. These signs are designed and installed by the Master Developer in conformance with Three Springs-specific criteria and are pertinent for road types defined in the Three Springs Codes & Standards. The signs may be changed out per seasonal messaging.

3.1.1 PRIMARY COMMUNITY IDENTIFICATION ENTRY AVENUE A ROAD TYPE

Medium-large profile sign located along the entry road to identify and market the Three Springs neighborhood to incoming traffic. The sign may be changeable with seasonal events, sales events/ pricing, leasing opportunities, and shall consistently identify Three Springs branding with directions to Information & Home Sales Center.

- Single faced; colorful sign with lifestyle, home products, and events imagery.
- Sign face - maximum size 8' h x 12' w
- Mounting location shall not take place at a ridgeline, and should be located with a sloped back ground and buffered by landscaping
- Ground clearance-5' min on longest leg and 3' min on shortest leg
- Posts- 6" x 6" x 1/4" weathering steel or rough sawn timbers of an appropriate dimension
- Concrete footer to be 18" diameter and a minimum 5' deep
- Copy area may include room for home builders, retailers, and events

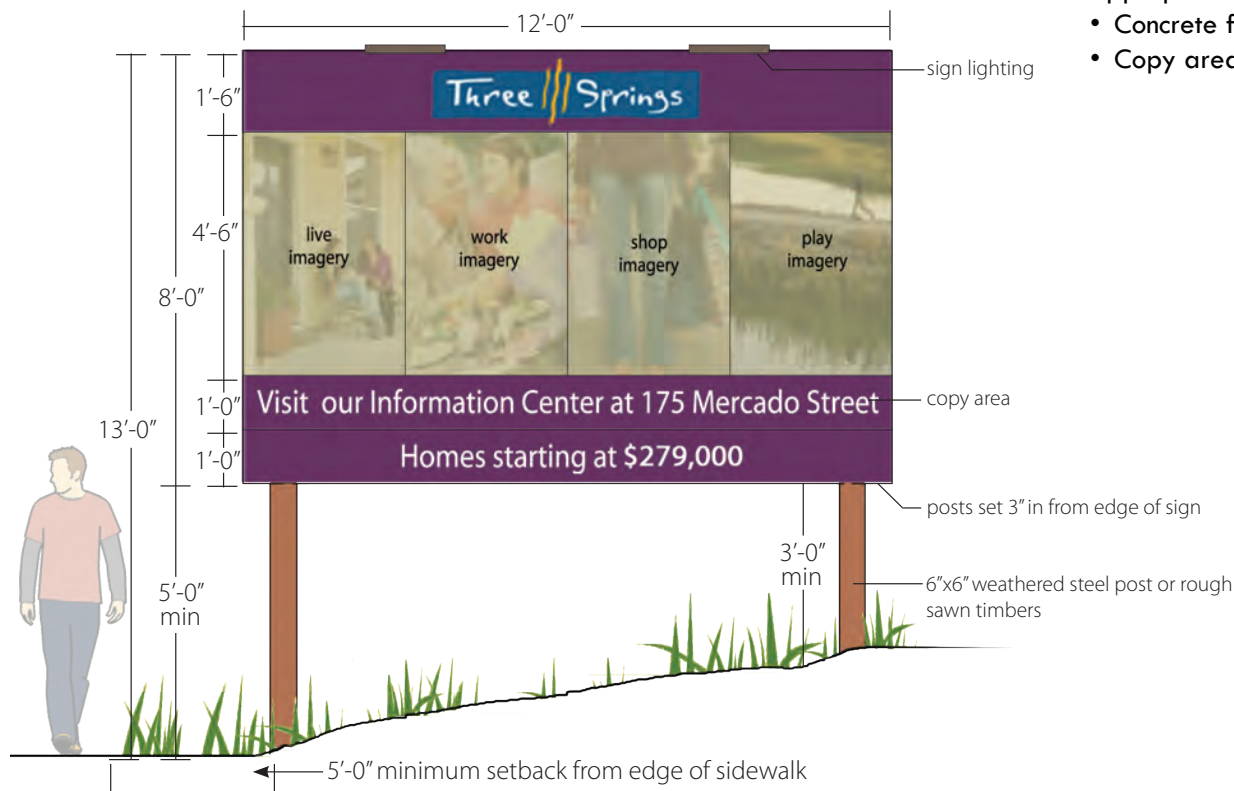

3.1.2 SECONDARY COMMUNITY IDENTIFICATION ENTRY AVENUE A AND B ROAD TYPE

Medium profile sign located along the Entry Avenue A and B road type to continue the identification/branding of Three Springs neighborhood to incoming traffic en route to Mercy Regional Medical Center and/or the Information & Home Sales Center.

Secondary Community Identification signs shall always be a companion sign to the Primary Community Identification sign and reflect consistent Three Springs branding. A comprehensive site plan for community identification signs (includ-

ing both primary and secondary) should be presented to the DRC to denote proposed locations. Identification signs may also be located on outbound routes of Three Springs in order to reinforce Three Springs Information.

- Single faced; colorful sign
- Sign Face maximum size 4' h x 8' w
- Maximum of two (2) additional drop down message panels allowed and shall not exceed 9" h x 6'-6" w each. Drop down panels available for homebuilders, retailers, or promotion of events.
- Ground clearance-4' at longest leg

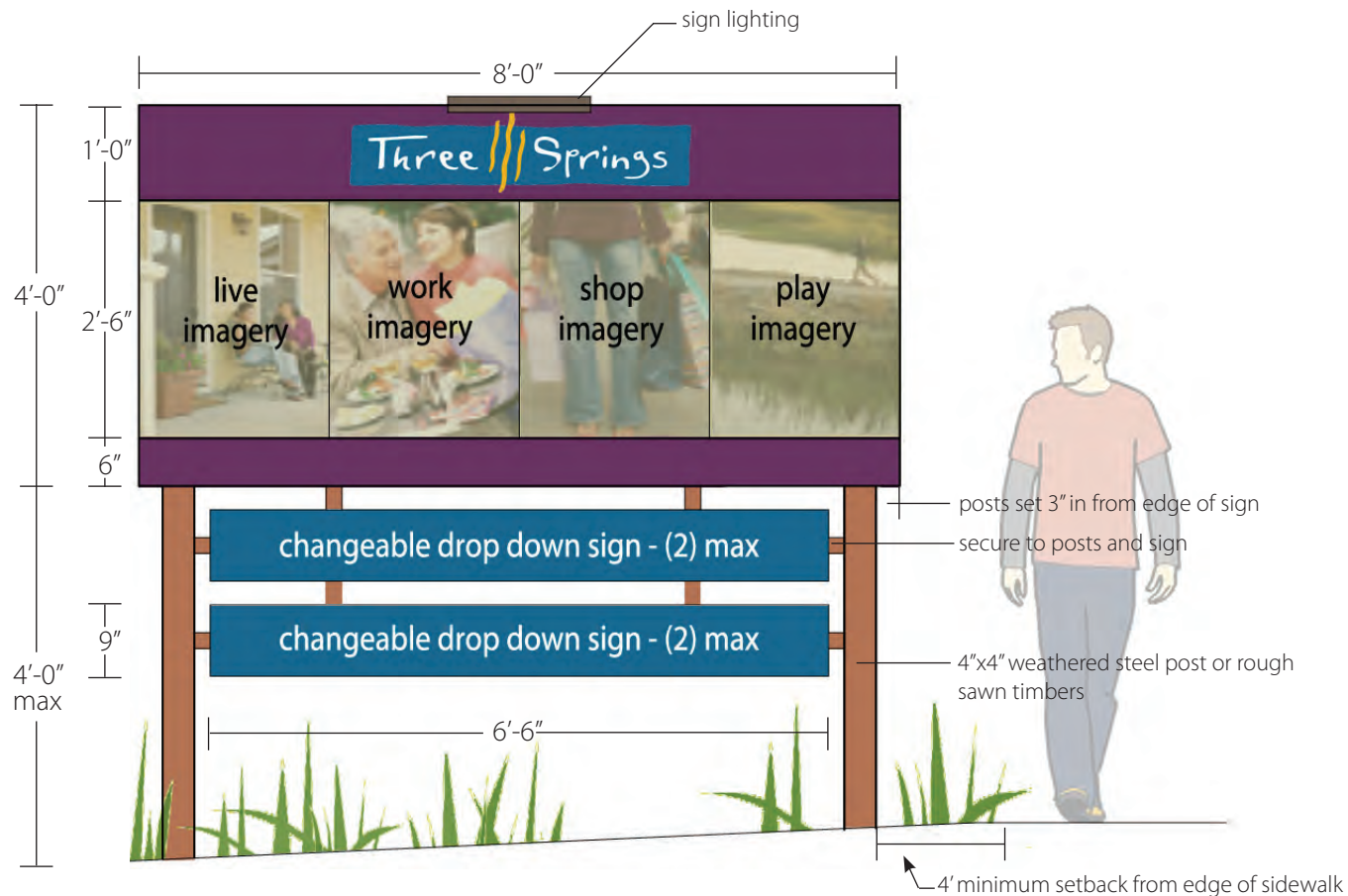

3.2 EVENT RELATED DIRECTIONAL SIGNS

These signs announce and direct traffic to specific events and may be put in place on the day of the event from 6 AM-9 PM. The signs should be designed per a Three Springs template (see Three Springs-specific criteria). The signs may be constructed or painted on corrugated plastic or other light weight materials and mounted on wire frames. Race events are allowed additional signs to mark a course for safety and convenience of participants.

- Sign face maximum size 24" height x 36" width
- Color: white background, blue letters, district logo
- Ground clearance to be 18"

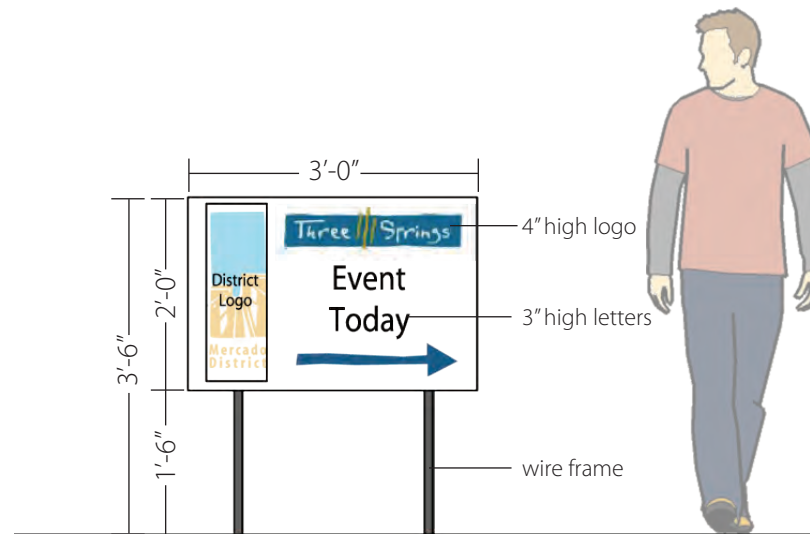

3.3 KIOSK

3.3.1 PRIMARY KIOSK

These kiosks consist of maps, master plan, site maps, directories, and or site information for both information and sales purposes. The primary kiosk consists of a cluster of information panels including master plans and electronic information designed for a site-specific, landscaped location where it is convenient for travelers to park and exit vehicles. The kiosk serves to orient visitors and provide up to date and diverse information for community, events, and sales purposes. Flyer boxes may be attached. In certain cases, the kiosk may contain a roof, flooring and overhangs and serve as a pavilion.

- Site specific with sizing and massing in relationship to the site and address pedestrian access
- Potential locations to be determined
- No L.E.D. sign face is allowed

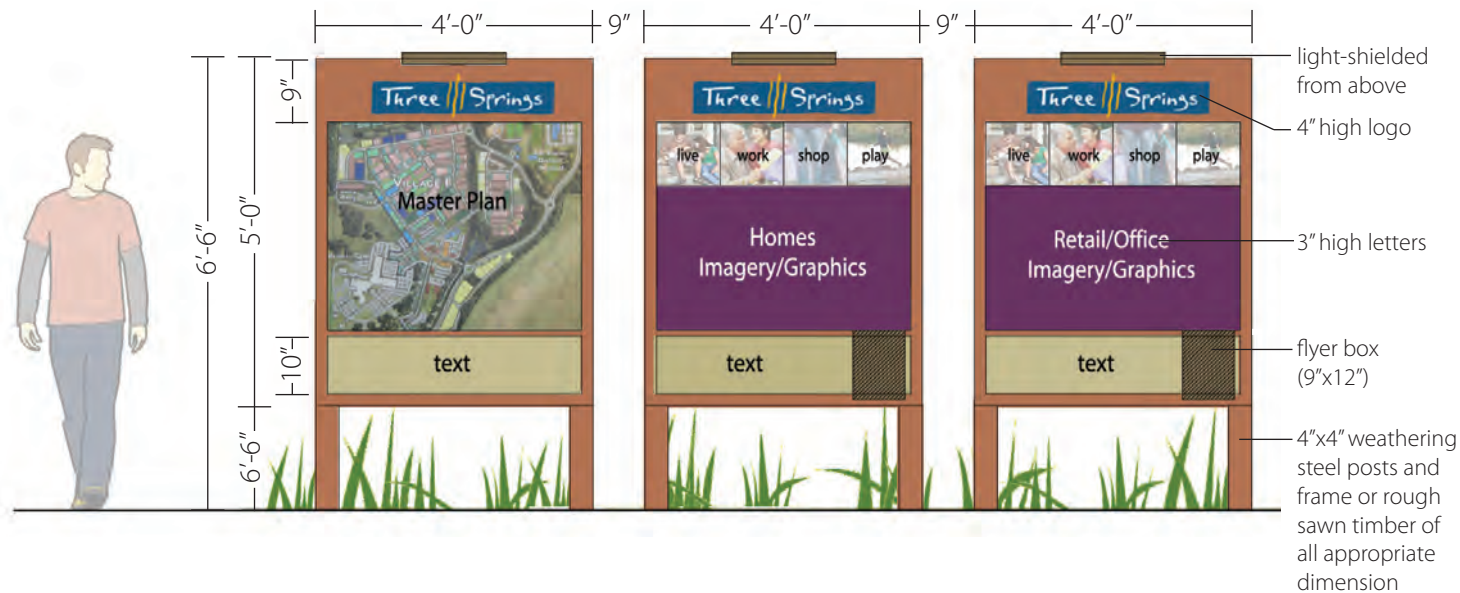

3.3.2 SECONDARY KIOSK

The secondary kiosk is a single unit with multiple sides in the pedestrian network in the mixed-use district with diverse and up to date information regarding the community, events, and pedestrian map information. The secondary kiosk serves as a temporary solution until monumentation for a permanent kiosk is defined.

- Site specific with sizing, massing, and messaging in relationship to site and pedestrian scale
- Included information: Message Reinforcement of Primary Kiosk
- Sign face to be 4'-6" h x 3' w
- Ground clearance to be 1'-6" h
- 4" x 4" weathering steel posts or rough sawn timber
- Double or triple sided
- This sign does not have to be "planted" in the ground. It can be free standing and moveable allowing flexibility in its location.

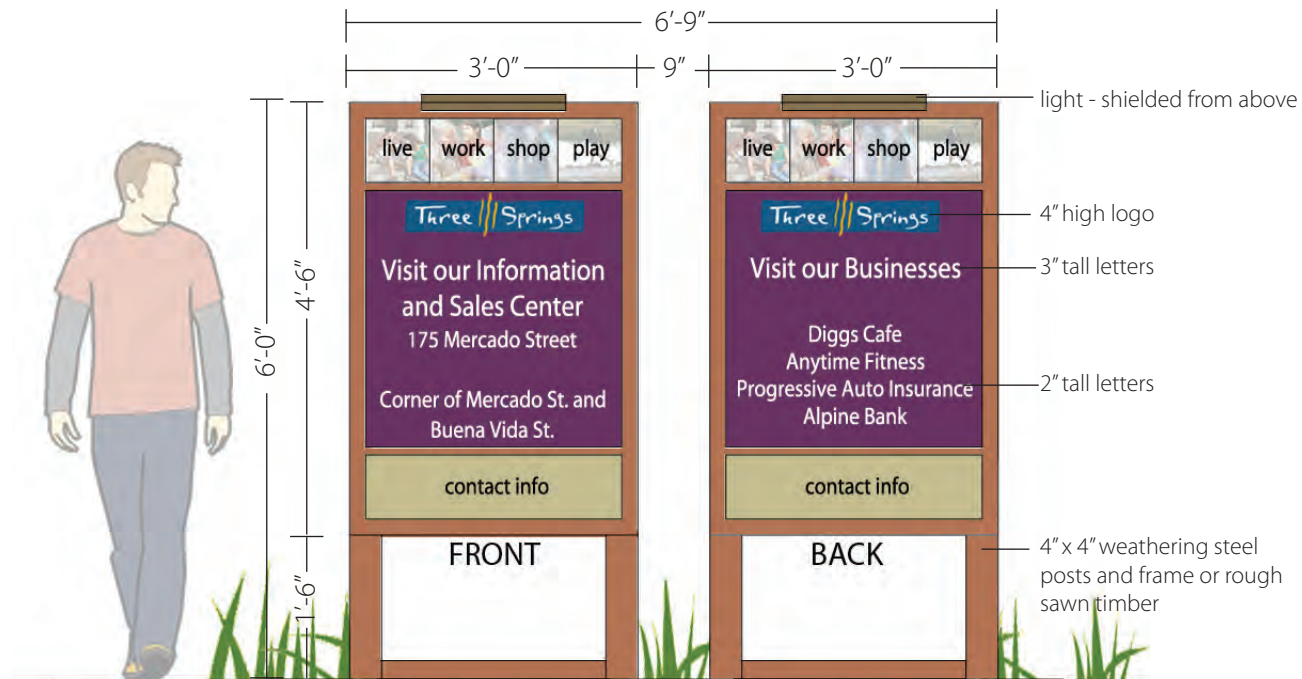

3.4 FUTURE SITE IDENTIFICATION

The sign announces a “future site of” (i.e., Future Site of Alpine Bank) and may identify timing and contact information. The sign consists of a template provided by the Master Developer to provide uniformity with Three Springs branding and provide space for owner-specific logo identification/contact information.

- Single-faced sign parallel to parcel or lot frontage
- Sign face maximum size 4' x 8' (landscape layout)
- Monumentation on a wood or steel frame with landscaping treatments
- Minimum ground clearance to be 3'
- Maximum of one Site Identification Sign per street frontage

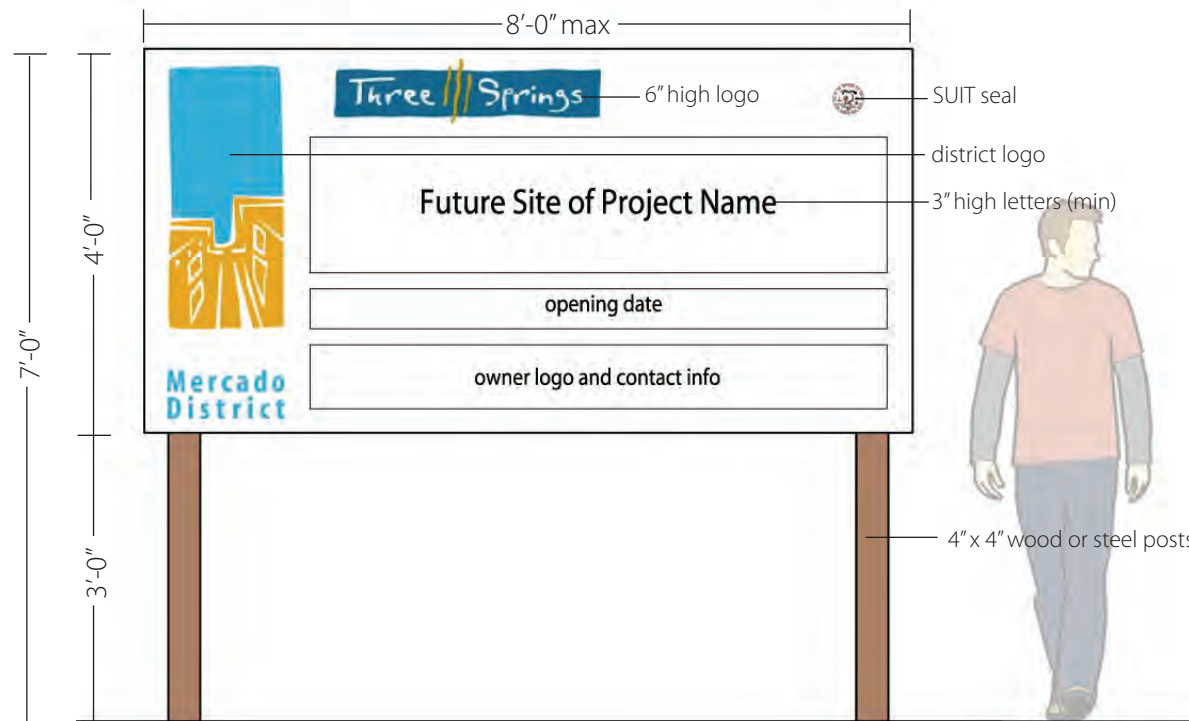

3.5 CONSTRUCTION IDENTIFICATION

The sign identifies the vertical construction of a project and lists contractors, architects, and contact information for leasing.

- Single-faced sign parallel to parcel or lot frontage
- Sign face maximum size 4' x 8' (landscape or portrait layout)
- Materials: colorful printed sign mounted on rigid backing
- Monumentation on a wood or steel frame or mounted directly to construction fencing
- Minimum ground clearance to be 3'
- Minimum 3" lettering
- Secure to temporary construction fencing
- One sign maximum per site

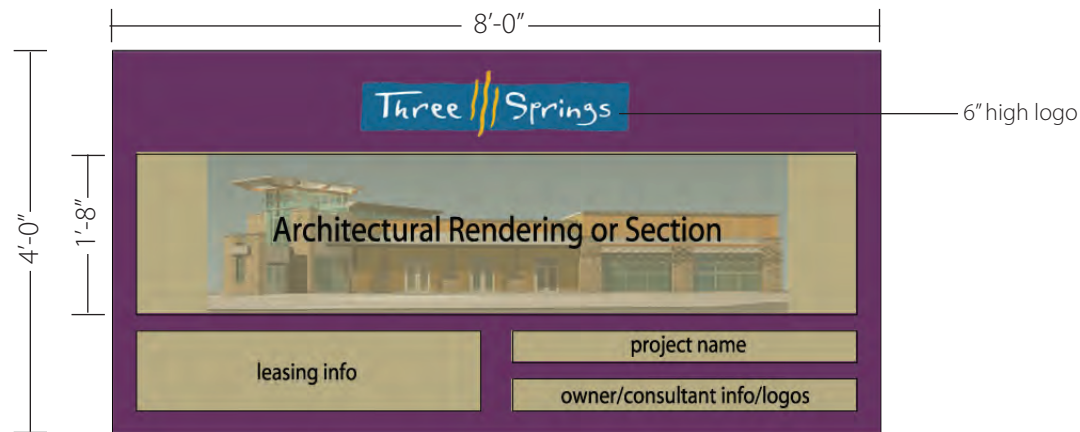

3.6 SITE ORIENTATION

The sign identifies an undeveloped site of a school, park, or community feature and provides a frame of reference of future development sites. The sign consists of a template provided by the Master Developer to provide uniformity with Three Springs branding.

- Single-faced sign
- Sign face maximum 8'h x 4'w
- Monumentation on a wood (4 x 4) or steel frame
- Ground clearance- 3'-0"
- Letter height to be 10"

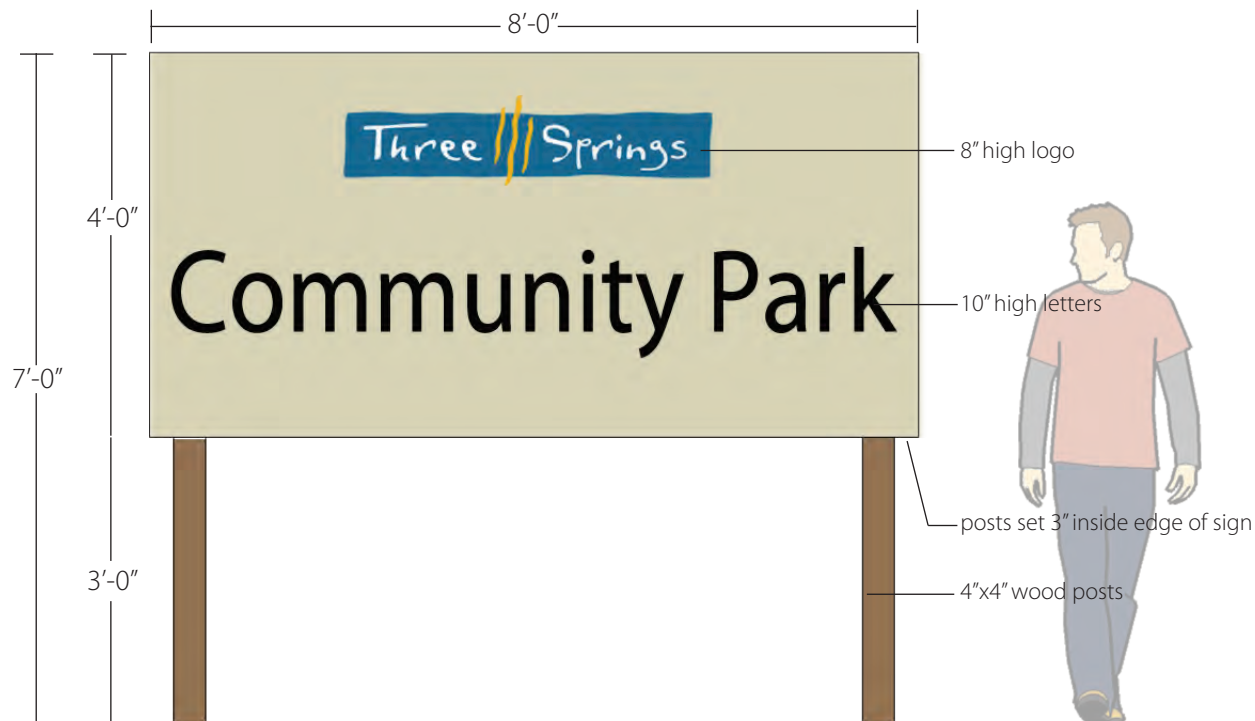

3.7 MIXED-USE PAD SITES

The pad site sign identifies a “for-sale” pad and provides sales contact information. The sign consists of a template provided by the Master Developer to provide uniformity with Three Springs branding. Each pad site may have one sign per street signage.

- Maximum of one single-faced sign per parcel street frontage
- Sign face maximum 4' x 4'
- Ground clearance-3'
- Post 4" square steel or rough sawn wood with optional landscape treatment at base

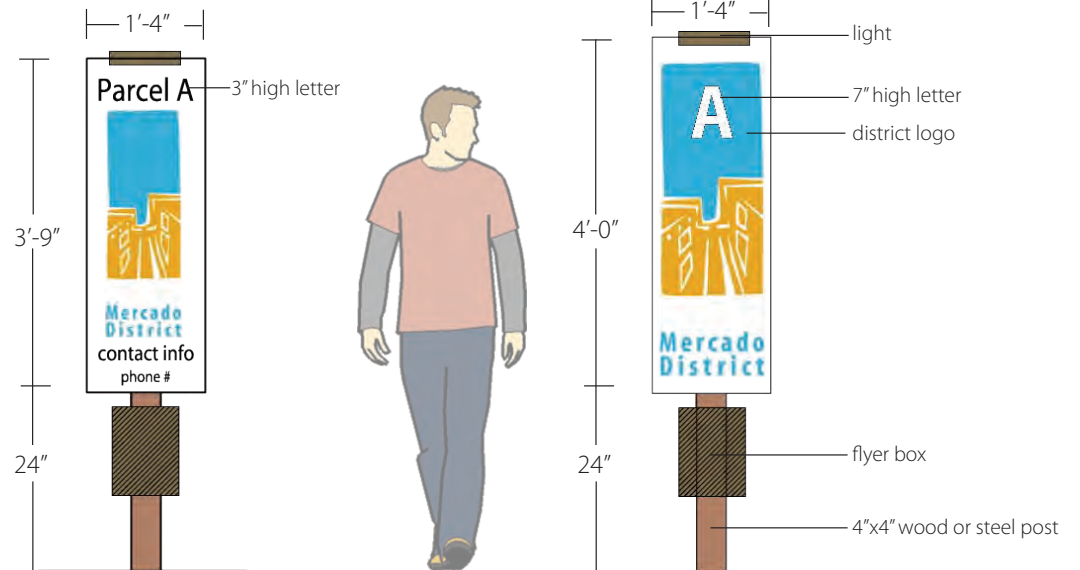
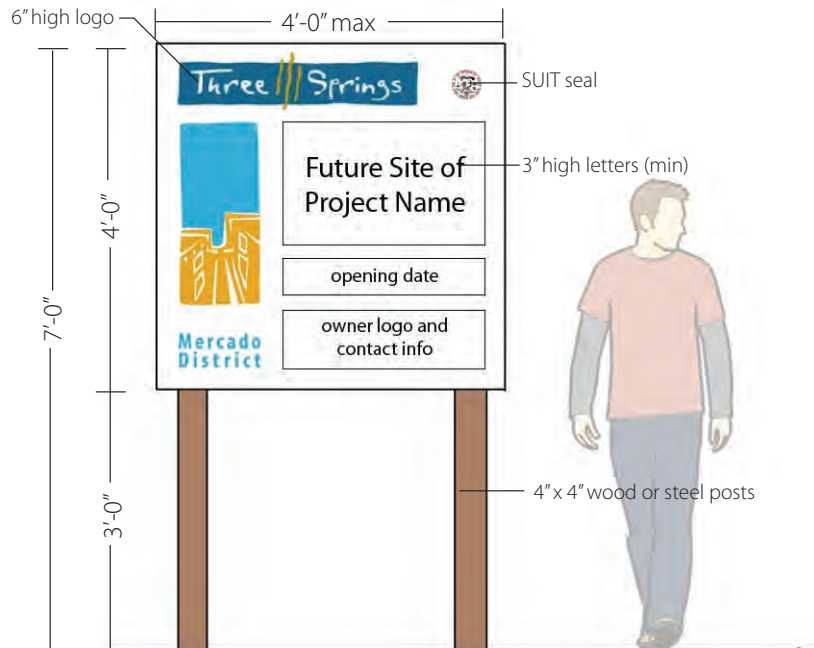

3.8 RESIDENTIAL BUILDER

The residential builder sign identifies townhome or apartment project and provides contact information for sales. The sign consists of a template provided by GRVP LLC to provide uniformity with Three Springs branding. The sign may be posted on the site during construction and prior to opening of the sales office/model home.

- One single faced sign parallel to the lot frontage or one double-faced sign placed at right angles to the lot
- Sign face maximum 34" h x 52" w
- Monumentation on a wood (4" x 4") or steel frame surrounding the sign
- Ground clearance to be 3'
- One drop down sign allowed with pricing/leasing information, 6" high
- Secure signs to top and side posts for stabilization
- Locate within yard

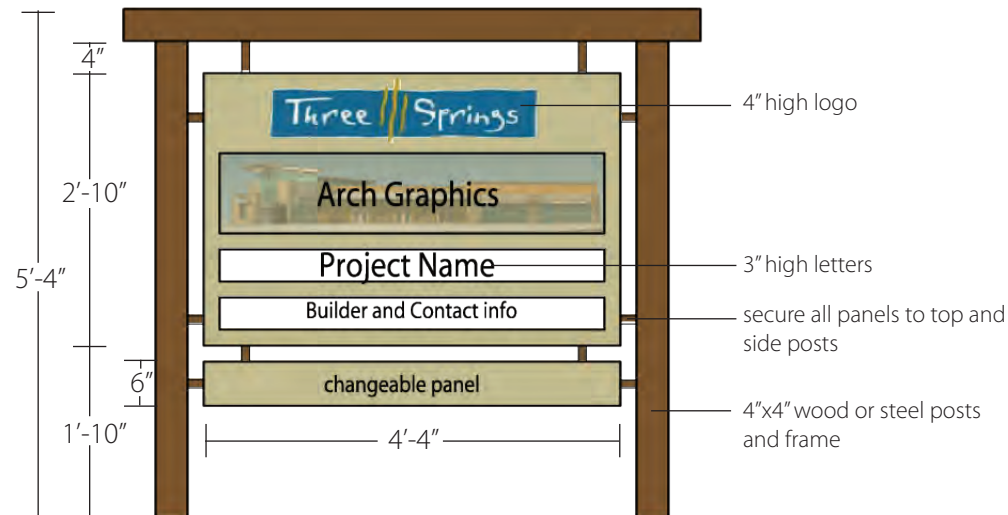

3.9 RESIDENTIAL FOR SALE

3.9.1 REAL ESTATE AGENCY/HOMEBUILDER

- Sign face may be irregular shape/form and may not exceed 720 sq inches (ie. 30" h x 24" w); real estate agencies may use their standard signs.
- Material to be metal
- Flyer boxes may be attached
- Sign shall be professionally designed and fabricated

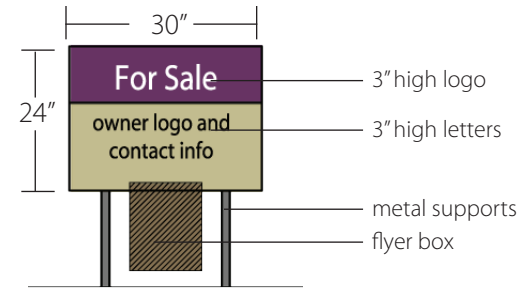

3.9.2 RESIDENTIAL FOR SALE - BY OWNER

- Sign face may be irregular shape/form and may not exceed 720 sq inches (ie. 30" h x 24" w)
- Flyer boxes may be attached
- Materials to be metal with a colorful face
- Sign shall be professionally designed and fabricated

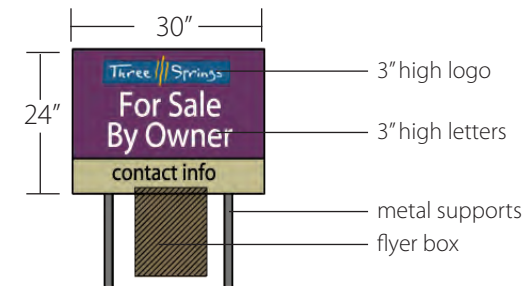

3.10 MAIN SALES CENTER

Site-specific signage may include a combination of flags, sandwich boards and the building mounted signage as approved in a Master Signage Program for the subject building and specific approvals of the DRC.

- Flagpole to be 25' tall and dark bronze
- Sandwich Boards (refer to 6-Sandwich Boards in the chapter)
- Flags to be 4'x6', color printed on fabric, and have UV coating for exterior use



3.11 EXISTING MODEL HOME

The existing model home site may be identified by a combination of insignia or logo flags for the residential builder and feather flags.

1) Insignia/Logo Flags

- Neighborhood flags may be posted at model homes to mark its location. The flag may bear the logo of the builder or the name of the project.
- Limited to two (2) flags per model home site including one Three Springs flag provided by the Master Developer and one insignia or logo flag of the builder/developer on a single pole located in front yard of the lot.
- Flagpole can be metal, carbon fiber, or fiberglass
- Maximum height of pole - 20' measured from ground level
- Maximum size of flag- 3' h x 5' w

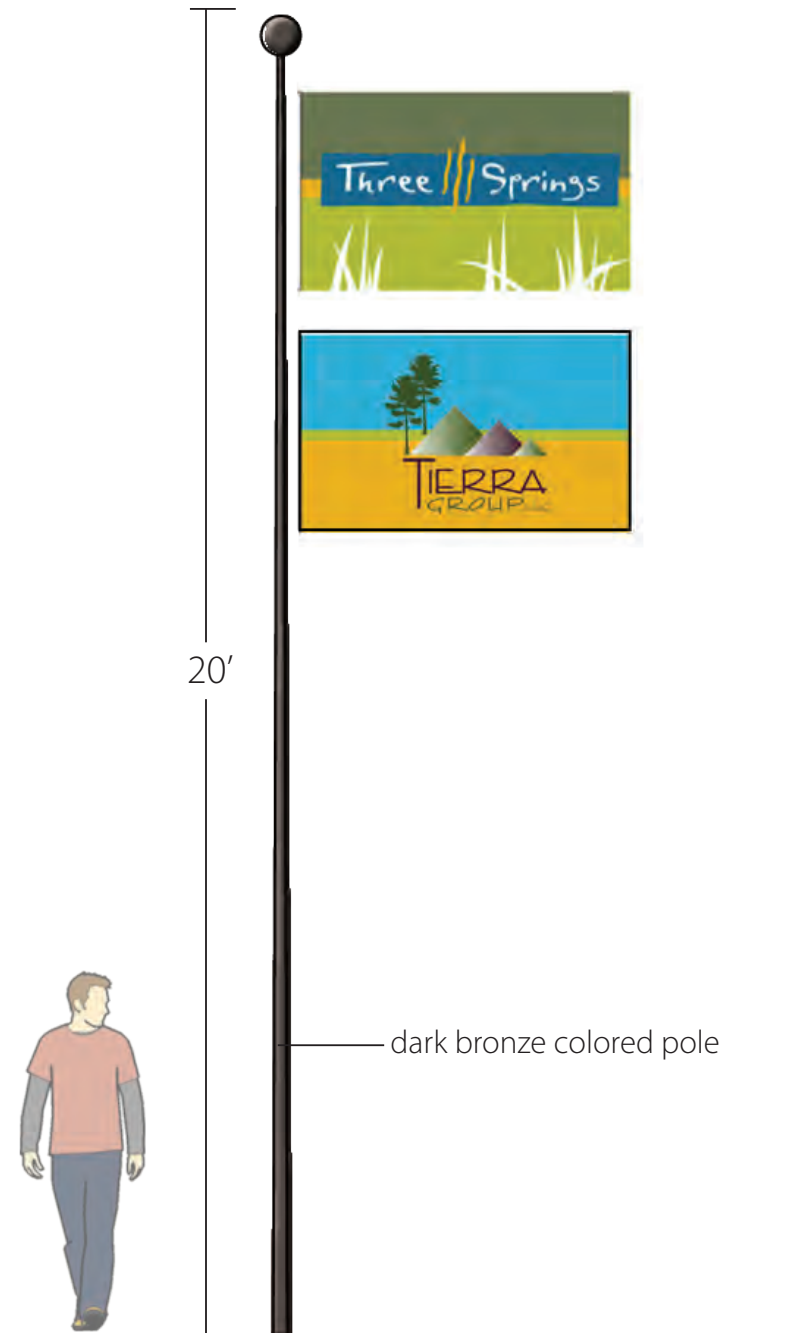

3.12 SALES TRAILER

The temporary sales trailer should be colorful and wrapped with lifestyle images and general information about sales opportunities

- Site-specific with sizing and massing in relationship to the site
- Landscaping around trailer is required
- Provide ADA accessibility



3.13 SANDWICH BOARDS

Sandwich boards are attached two-sided tent signs primarily utilized for special and sales events at the pedestrian level. Prior to construction of permanent directional signage, roadway signage boards may also be utilized. These signs may be placed in the right-of-way with the approval of the City of Durango-Public Works Department.

a) Roadway

Roadway sign boards are provided at strategic locations to provide directions to the Information & Sales Center and a model home.

- Maximum size allowed is 3'-2" h x 2'-1" w

b) Mixed-Use

Mixed-use sign boards announce open hours/location and/or sales events.

- Maximum size allowed is 4'-0" h x 2'-11" w
- Placed on the sidewalk outside a retail/office entry between the door and the planter box. If sign is placed in right-of-way, City of Durango-Public Works Department must approve location.

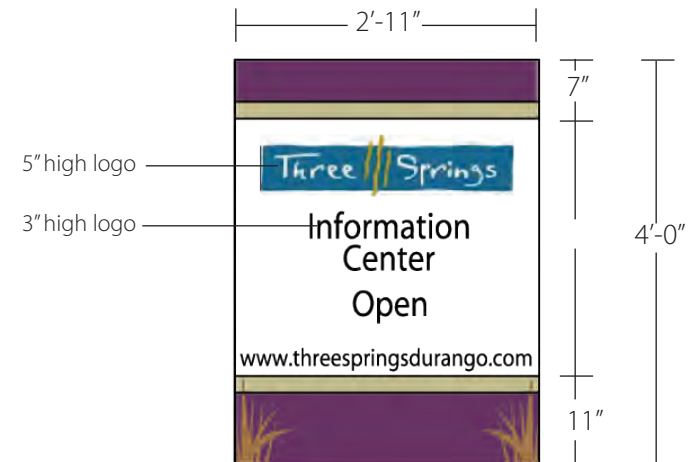
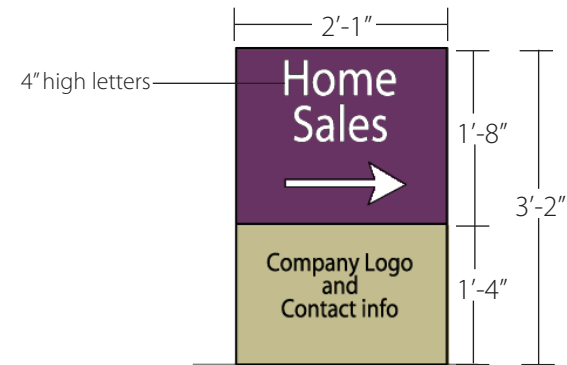

3.14 ORNAMENTAL SIGNAGE

Roadway ornamental signage consists of entrance flags, roadway and district banners and event banners to call attention to entry points and to serve as wayfinding features leading to or announcing an entry to the community, a district, the plaza, or a neighborhood including special events.

3.15 ENTRANCE FLAGS

Community Entrance Flags may be used during the early phases of development to call attention to the main community entrance and provide monumentation. The flags may be grouped (maximum of three) as part of an entry monumentation and become part of a permanent monument at a later date. Height of flagpoles to be staggered.

- Limited to community entrance gateway locations
- Dark bronze anodized pole
- Maximum height of pole- 50' measured from ground level
- Maximum wind speed tolerance-115-125 mph
- Flagpole's concrete footers need to be approved by a structural engineer
- Flags should be illuminated to allow for 24 hour display

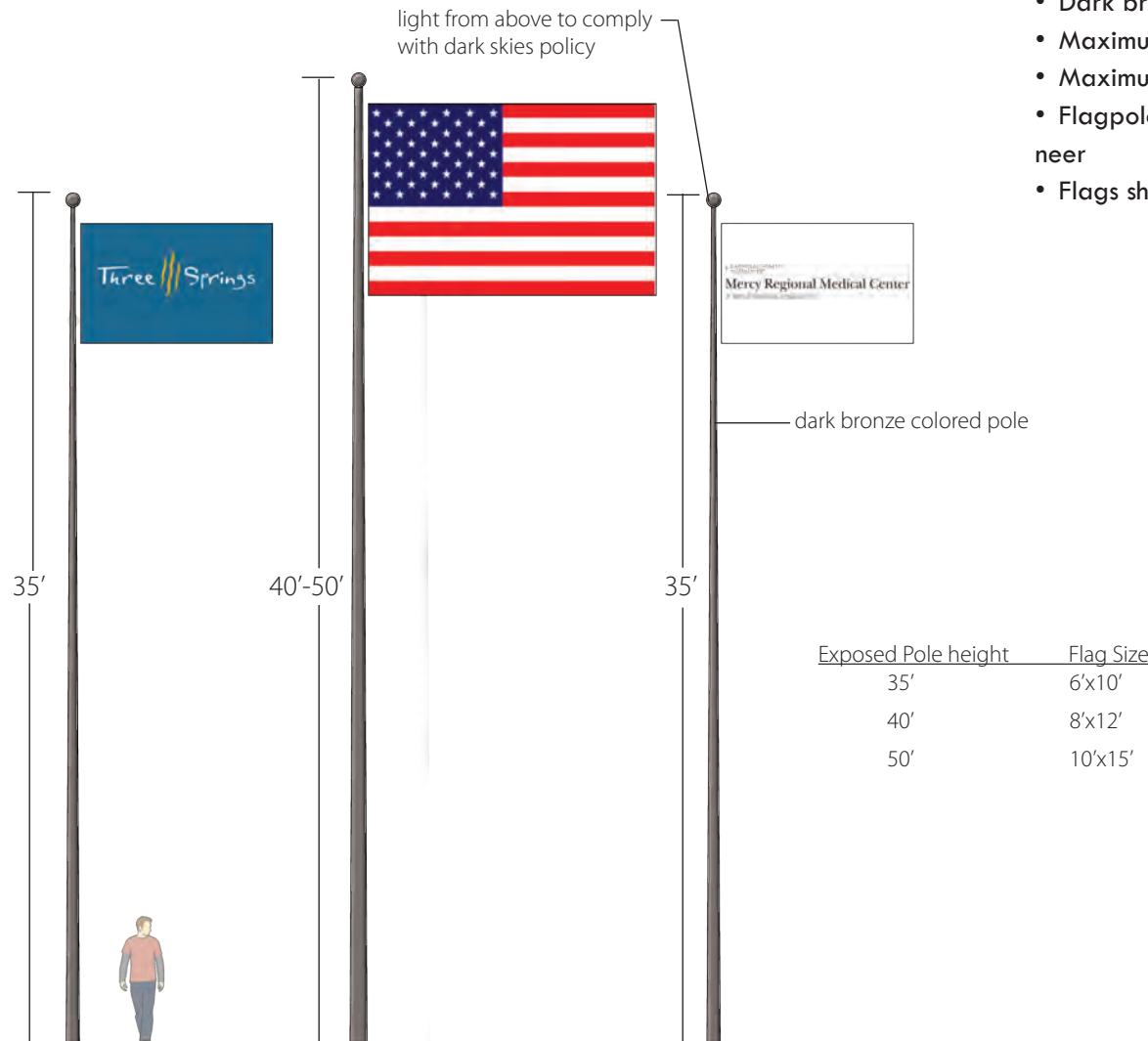

3.16 FEATHERED FLAGS

Windfeather-type flags (with streamers) mounted on a fiberglass pole and used to identify a model home or open house site. These feathers may be in place between 6 AM-9 PM.

- Maximum of two (2) flags per model home
- Maximum size of feather 16.5' h (including base of pole) and 2.5" in width

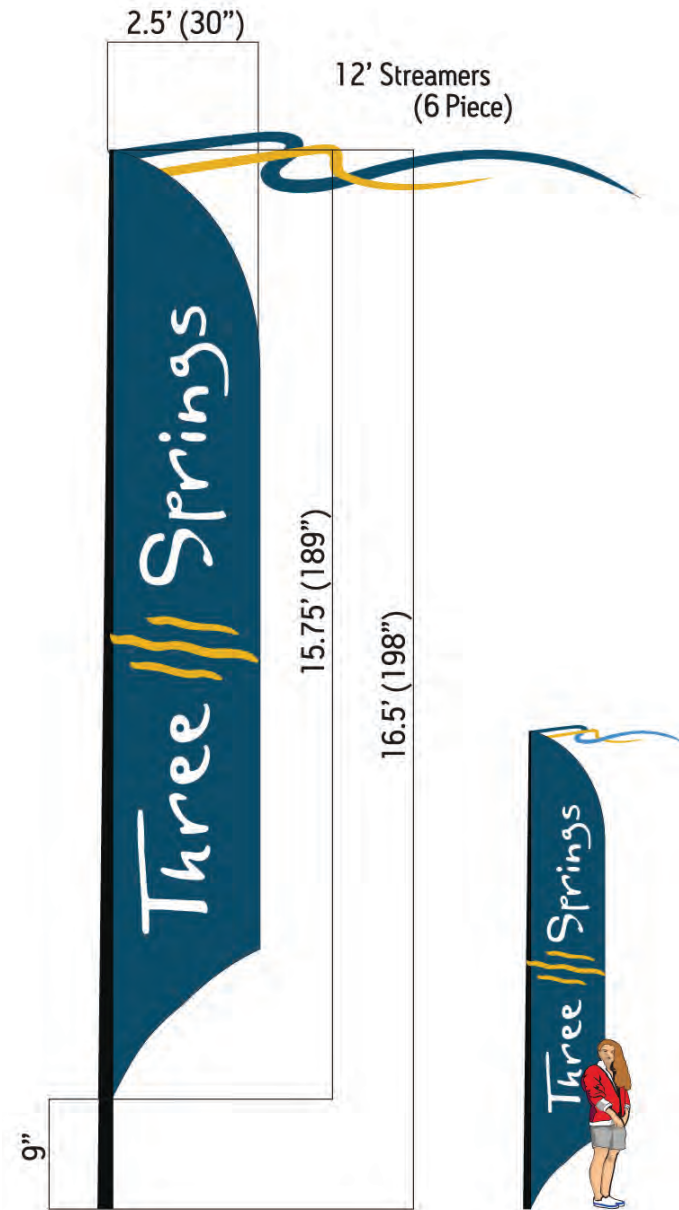

3.17 BANNERS

3.17.1 ENTRY ROAD

Changeable banners attached to street lights to identify the route and convey lifestyle images of Three Springs branding and/or neighborhood icons

- Light pole Banners may not exceed 6' h x 3' w
- Placement shall be at a consistent height visible and legible for both pedestrians and vehicular drivers
- Banners shall be limited to spacing on alternate light poles
- Minimum ground clearance-12' h measured from base of light fixture at ground to bottom of banner
- Attachments details TBD- prefer direct attachment to pole
- Banner Size needs to be approved by a structural engineer

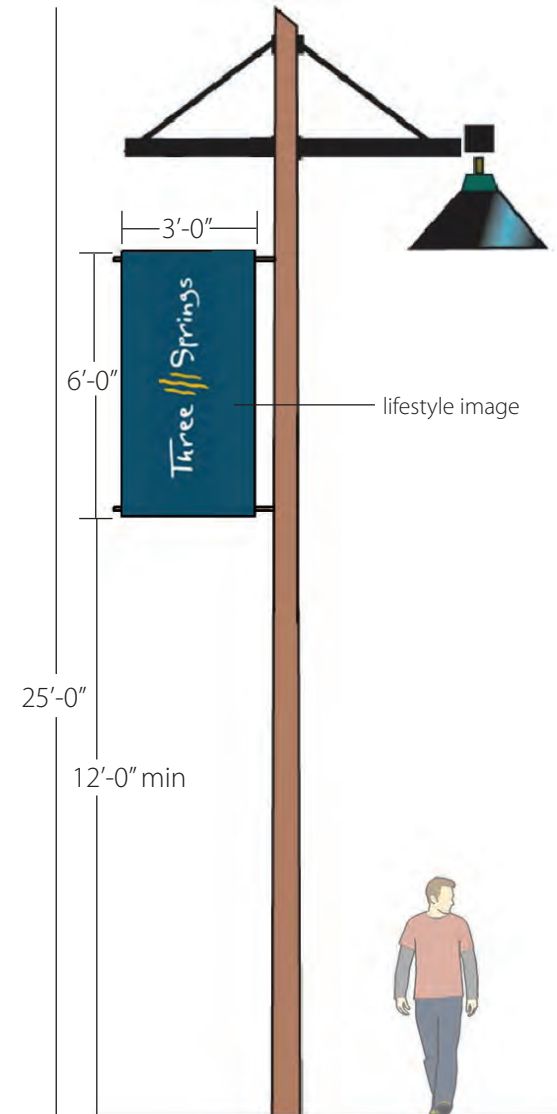

3.17.2 DISTRICT

Changeable banners attached to street lights in the pedestrian District/Neighborhood to identify the route to and/or within a venue and convey lifestyle images of Three Springs branding and/or neighborhood icons

- Banners may not exceed 48" h x 22" w
- Minimum ground clearance 8' measured from base of light fixture at ground to bottom of banner
- Attachments details TBD- prefer direct attachment to pole
- Banner Size needs to be approved by a structural engineer

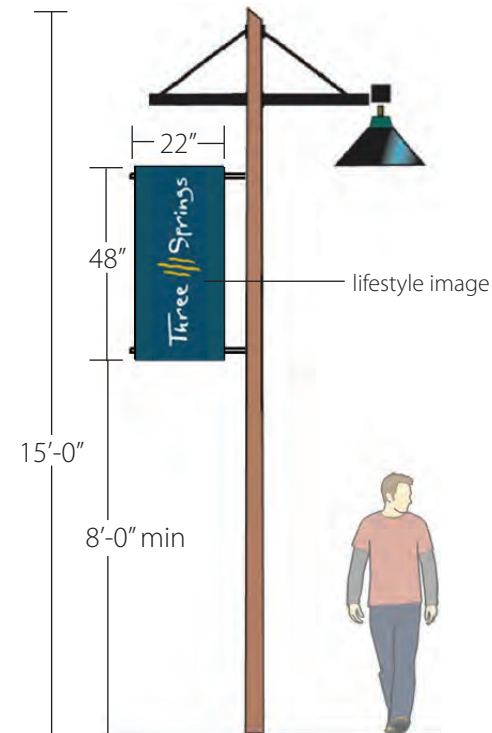

3.17.3 MIXED-USE STREET

Temporary banner hung across Mercado Street or other designated mixed use street as approved by the City of Durango- Public Works Department to announce events or community campaigns. The Mercado Street banner is mounted to 125 Mercado Street and the tower in the plaza. Additional sites may be identified with build out of the mixed use district.

- Maximum 3' h x 40'w
- Mounted minimum 14' from the ground level
- Minimum clearance over road 14'-0"
- Printed on both sides
- Banners must have wind load slots

