

THREE SPRINGS DESIGN GUIDELINES

FENCING AND WALL STANDARDS

ORIGINAL ADOPTED: JUNE 12, 2006
MINOR AMENDMENT: DECEMBER 2012
MINOR AMENDMENT: MARCH 23, 2017



TABLE OF CONTENTS: FENCING AND WALLS

1.0 INTRODUCTION	1
2.0 RESIDENTIAL FENCING AND WALLS	1
2.1 FRONT FENCING AND WALLS	2
2.2 SIDE AND REAR FENCING AND WALLS	3
2.3 SIDE AND REAR FENCING AND WALLS ADJACENT TO PARKS AND OPEN SPACE	3
3.0 MIXED-USE, SPECIAL DISTRICTS AND OTHER FUNCTIONS	4
4.0 TRASH ENCLOSURES	4

EXHIBITS

EXHIBIT A - RESIDENTIAL FENCE DIAGRAM

EXHIBIT B - RESIDENTIAL FENCE DIAGRAM - ADJACENT TO PARKS AND OPEN SPACE

EXHIBIT C - PERIMETER OPEN SPACE FENCE DETAIL

1.0 INTRODUCTION

These Fencing and Walls Design Guidelines (Design Guidelines) define the design objectives and standards for fencing and walls in the Three Springs Neighborhood. The purpose of this supplement is to assist designers, single-family and multi-family home builders, contractors, and property owners as to the range of acceptable fence and wall design options and materials available to create safe, secure and aesthetically diverse public and private fencing and walls in the Three Springs Neighborhood. This supplement serves to encourage all property owners, builders and developers to consider a wide variety of fencing and wall design options for individual lots and parcels by outlining an acceptable palette of materials and essential design standards as necessary.

In general these criteria are intended to provide a set of 'guidelines' and in some cases 'standards' to protect the health and safety of individuals. The guidelines are not intended to be prescriptive in nature but rather to ensure a level of quality and design variation for fencing and walls is maintained throughout the Neighborhood.

The guidelines apply to all fencing and walls regardless of Transect, lot type and use within the Neighborhood, including; residential, multifamily, mixed-use, and variable lot types.

Appropriate fence and wall typologies include Front Yard, Side Yard and Backyard fence applications as necessary.

All fencing and wall design shall be in keeping with the vision and principles outlined in the Three Springs Design Guidelines.

The fencing and walls design criteria apply to all development within the Three Springs Neighborhood. Review and approval of all on-site fencing and walls is required by the Three Springs Design Review Committee (DRC).

The Transect is a system of classification employing the conceptual rural-to-urban continuum defining a useful order of the typical elements of urbanism. The Transect is a natural ordering system where every urban element finds a place within its continuum. Fencing and walls, like any other element in the continuum, is defined differently depending on the location within the community.

Guidelines

a. The transition between the public and private spaces should be carefully addressed through landscape plant material choices, grading and hardscape to provide a seamless transition between the public right-of-way (sidewalk area) and the private lot (front yard).

b. Durable and generally maintenance-free fencing and wall materials should be used whenever feasible.

Standards

a. Galvanized chain link fencing material is strictly prohibited. Vinyl coated chain link fence, as used at the LPEA station, is allowed in multi-use and special districts only.

b. Applicable fencing design standards related to Americans with Disabilities (ADA) shall apply when ever required.

c. Newly constructed fences and/or walls on a property shall not adversely affect existing (constructed) site drainage on the property or neighboring property in any way.

2.0 RESIDENTIAL FENCING AND WALLS

Principles

Provide variation in fence design to respond to the individual site, architectural styles and materials on the site as necessary. Fencing and wall designs should compliment the architectural styles and exterior finishes of the principal structure when ever feasible.

Guidelines

a. Generally a consistent height for the top of a wall or fence is encouraged, recognizing that the design of the fence or wall may vary.

b. Fencing and walls should be placed in locations that are meaningful for aesthetic and practical use.

c. Some interest and variety in the wall and fence design and alignment is encouraged in Three Springs.

d. Traditional fence materials (wood, stone, metal, masonry) are preferred on Three Springs' residential lots. However, products are being developed that incorporate recycled and/or renewable resources. Therefore, DRC will give consideration to fence materials such as vinyl, plastic, or metal that are a heavy gauge and in a traditional shape and size.

Standards

a. All fence design shall be reviewed and approved by the DRC.

b. All fencing and walls shall complement the architectural style of the house and shall be appropriate in materials, color, and style.

c. Material transitions shall be made at inside corners.

d. All mechanical equipment must be screened from view with a fence or wall. Mechanical screens must be a minimum of twelve inches (12") above the height of the equipment.

e. The exposed structural framework side of the fence shall be oriented to the interior of the lot.

f. Approved residential fencing materials include: wood, steel, cable, steel mesh, stone columns, recycled material, and CMU. Alternative materials are reviewed on a case by case basis.

g. Chain link fencing is not acceptable for residential fencing.

2.1 FRONT FENCING AND WALLS

Principles

Front fences and walls help to define the semi-public space of the front yard, and to differentiate this semi-public space from the public space of the sidewalk and thoroughfare. Fences and walls can enhance the transition between public and private realms and can also add to the character of the streetscape and neighborhood as a whole.

Guidelines

a. Front yard fencing is allowed as long as it enhances the landscape.

b. Fencing along parks and open space shall be consistent in design, material, height across all of lots facing parks and open space.

Standards

a. Free standing front fence or wall dimensions:

maximum height: 48"

post spacing: 8'

end post size: 4" minimum square

intermediate post size: 2" minimum square

open: 50% minimum

pickets: vertical or horizontal

b. Entry gates and arbors are permitted, provided they are attached to a fence or wall, or bordered by a hedge. Gates should be in proportion to the fence or wall, and may be a maximum of forty-eight inches (48") in height. Gate and arbor materials should match or complement those of the fence or wall, as well as those of the house.

c. Front yard fencing may be placed on top of a wall provided that the total height does not exceed forty-eight inches (48"). In the case of fences on retaining walls, the total height may not exceed sixty inches (60") and is measured from the base of the retaining wall.

d. Individual retaining walls shall be a maximum of forty-eight inches (48") in height. If taller walls are required, then the walls shall be terraced so that each wall does not exceed forty-eight inches (48") in height.

e. Retaining walls shall be constructed of durable materials, such as stone, brick, or concrete, and allow for the drainage of water from behind the wall.

g. Courtyard walls that enclose a semi-private space immediately adjacent to the house are permitted. A minimum of sixty percent (60%) of a courtyard wall should match the material of the house wall, but other complementary materials may be used as ornament.

h. The maximum height of courtyard walls is forty-eight inches (48") and they should be set back a minimum of ten feet from the front property line. If a courtyard wraps around the side of the house, the walls may increase to a maximum of six feet (6') in height along the side property line.

i. Features such as fountains, planters, or barbecues may be incorporated into courtyard walls.

j. The fences or walls that face into a common green area are considered front fences or walls. In this case, any fence or wall at the front of the houses should be consistent across all the houses bounding that particular space.

k. Fences or walls, if used, should be consistent in character along the entire front of a building, rather than being individualized for each unit.

l. Transition of fence height from Front Yard to Side Yard fencing shall occur at intersections of perpendicular fence lines (a minimum of ten feet (10') beyond the front building elevation).

2.2 SIDE AND REAR FENCING AND WALLS

Principles

Side and rear fences provide private, usable space for residents, and screen outdoor areas from alleys and adjacent buildings.

Guidelines

a. Side and rear fencing and walls should provide privacy in a way that is attractive and complements the architecture of the house and neighborhood.

b. Since the function of side and rear fences and walls is primarily one of screening, a minimum of 2/3 of the height of the fence or wall should be solid.

c. Side Yard fence locations should minimize establishing narrow and unusable lot area as much as possible. Limit Side Yard fencing when ever possible. In many instances, side yard fencing may not be appropriate.

Standards

a. Free standing rear and side fence dimensions:

Maximum height: 6'

Post spacing: 8' on center

Posts: 4" square posts or comparable metal posts

b. Single Family specific: Side yard privacy fencing and walls shall connect to the side of a house a minimum of ten feet (10') back from the front corner of the wall plane of house. See Exhibit A: Residential Fence Diagram.

c. Multi-Family specific: Side yard fencing and walls shall connect to the side of a building a minimum of two feet back from the front corner of the building.

d. Rear fences built along alleys shall be setback three feet (3') from the rear property line.

e. Side and rear fences shall not exceed six feet (6') in height.

f. Side yard fences that abut a street right of way shall not exceed six (6') feet in height and shall have a minimum of fifty percent (50%) open total surface area above four feet in height (4'). On a case by case basis, the DRC may grant a waiver to this "open requirement" for a street side yard fence that is across the street from an existing solid fence (i.e. homes along Clear Spring Avenue). See Exhibit A: Residential Fence Diagram.

2.3 SIDE AND REAR FENCING AND WALLS ADJACENT TO PARKS AND OPEN SPACE

Principles

The side and rear fences on lots adjacent to parks and open space are intended to delineate the boundary of residential uses and public open space. It shall create private usable space around the home while not detracting from the benefits of the adjacent natural lands.

Standards (transects T3 and T4 with lots adjacent to parks and open space)

a. Perimeter Fence dimensions

Maximum height: 48"

Post spacing: 8' maximum on center

Posts and rails: per DRC approved detail (refer to page 7)

b. Perimeter fencing shall be constructed along common property lines between residential lots and parks/open space and shall be 3 rail design approved by the DRC; refer to page 7.

c. Privacy screen fencing and garden walls to be inside of rear lot setback; within the building envelope of individual residential lots for the purpose of enclosing or screening a patio, spa, hot tub, or outdoor living area at the rear or side of the home. Such enclosures shall be consistent with the architectural character and materials of the home and shall appear as an integral extension of the home.

d. Privacy screen fencing to be a maximum height of 6' and can only be a maximum of 50% of the lot width.

e. All privacy screen fences and garden walls shall be painted or stained to match or compliment the house and present the finished side out.

f. Unfinished masonry walls including those constructed of CMU block and split face block shall not be permitted.

g. Side yard privacy fencing shall transition from a maximum height of 6' to the height of the 3 rail perimeter fence. As a minimum, the height transition shall begin a minimum of 8' from the 3 rail perimeter fence.

See Exhibit B: Residential Fence Diagram Adjacent to Parks and Open Space

Standards (T4 lots adjacent to parks/open space and Arterial Street)

a. For lots that are adjacent to a park or open space and an Arterial street, the DRC may approve a 6' privacy screen fence or wall. In such cases, the privacy screen fence or wall shall present a consistent appearance from lot to lot. From lot to lot the fence/wall shall match in height, materials, color, finish, detailing, etc. This standard has been applied to lots 48-55 in Village 1, Filing 3.

3.0 MIXED-USE, SPECIAL DISTRICTS AND OTHER FUNCTIONS

Guidelines

a. Encourage owners to use more custom artistic fences.

b. Schools and Sport Fields may use vinyl coated fencing similar to the fencing used at the electrical substation.

c. Industrial Districts are encouraged to use raw/non-galvanized steel, some vinyl coated fencing may be appropriate.

d. Encourage grid pattern fencing apposed to the chain link woven pattern.

Standards

Approved mixed-use fencing materials include: wood posts, steep posts, wood slats/pickets, steel cable, steel mesh, stone columns, recycled material, and CMU. Approved treatment to wood include: rough saw cut, aged barn wood, painted, and white washed. Approved treatment to steel include: weathered, painted, powder coated, and core-ten.

4.0 TRASH ENCLOSURES

Standards

a. The City of Durango will provide trash receptacles and recycle material containers for homes in Three Springs. Each property shall provide a location for trash enclosure and recycled materials as necessary.

b. Each property shall provide a location to screen all receptacles from the alley, either behind the property fence or within a storage area or in the garage.

c. If providing a trash/recycle bin enclosure, fabricate the enclosure of a similar form, material and color as the property fence or building architecture.

d. Ensure the screening is twelve inches (12") higher than the object being screened up to a maximum of six feet (6').

e. In the case of lots with alley access, City Services will designate a common collection point in the alley to be used on the days they pick up trash/recycle materials.



Example of 50% open above 4' on side yard fences that abut a street right-of-way and side wall plane to the side property

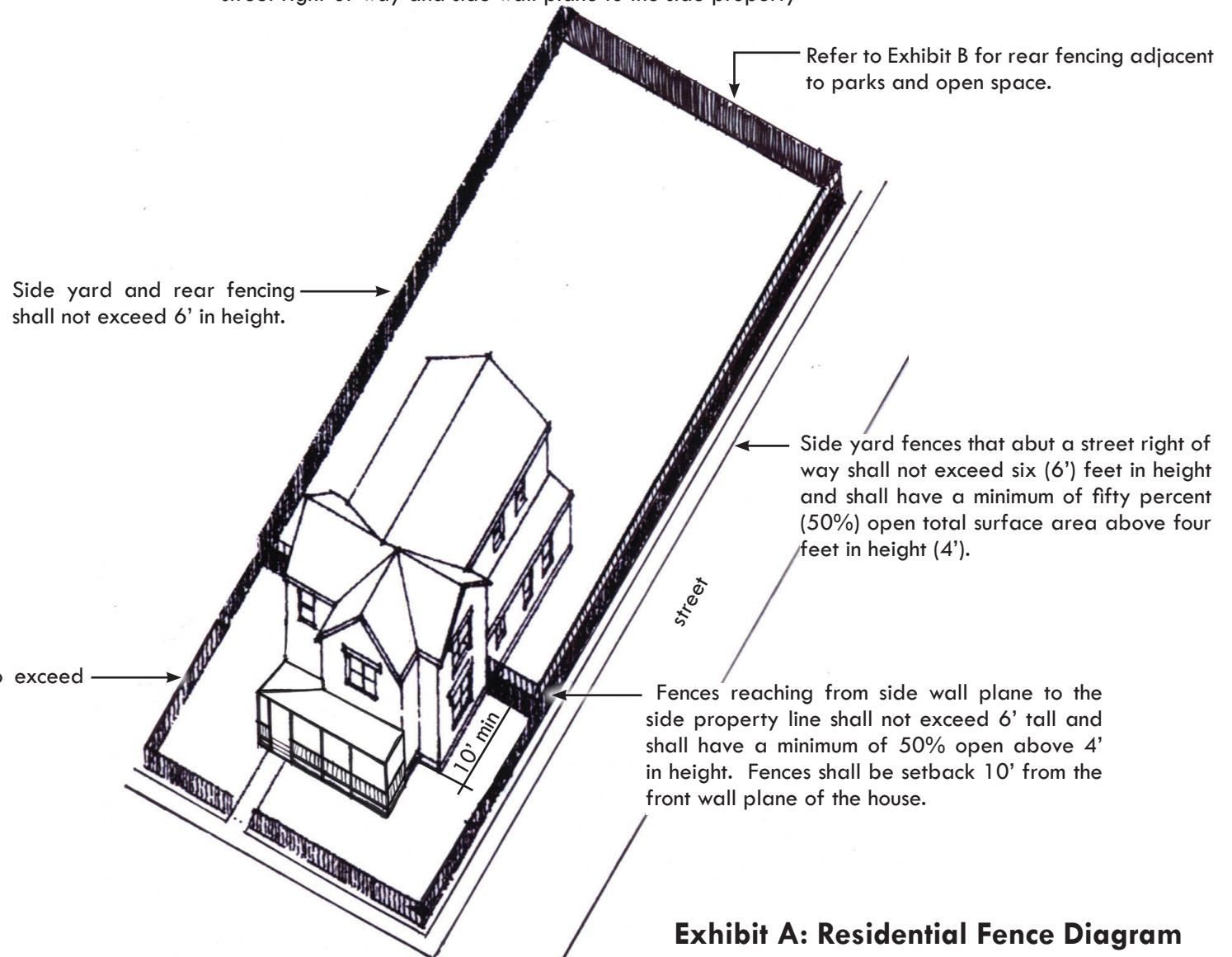

Side yard and rear fencing shall not exceed 6' in height.

Refer to Exhibit B for rear fencing adjacent to parks and open space.

Side yard fences that abut a street right of way shall not exceed six (6') feet in height and shall have a minimum of fifty percent (50%) open total surface area above four feet in height (4').

Front yard fences shall not to exceed 48" in height.

Fences reaching from side wall plane to the side property line shall not exceed 6' tall and shall have a minimum of 50% open above 4' in height. Fences shall be setback 10' from the front wall plane of the house.

Exhibit A: Residential Fence Diagram

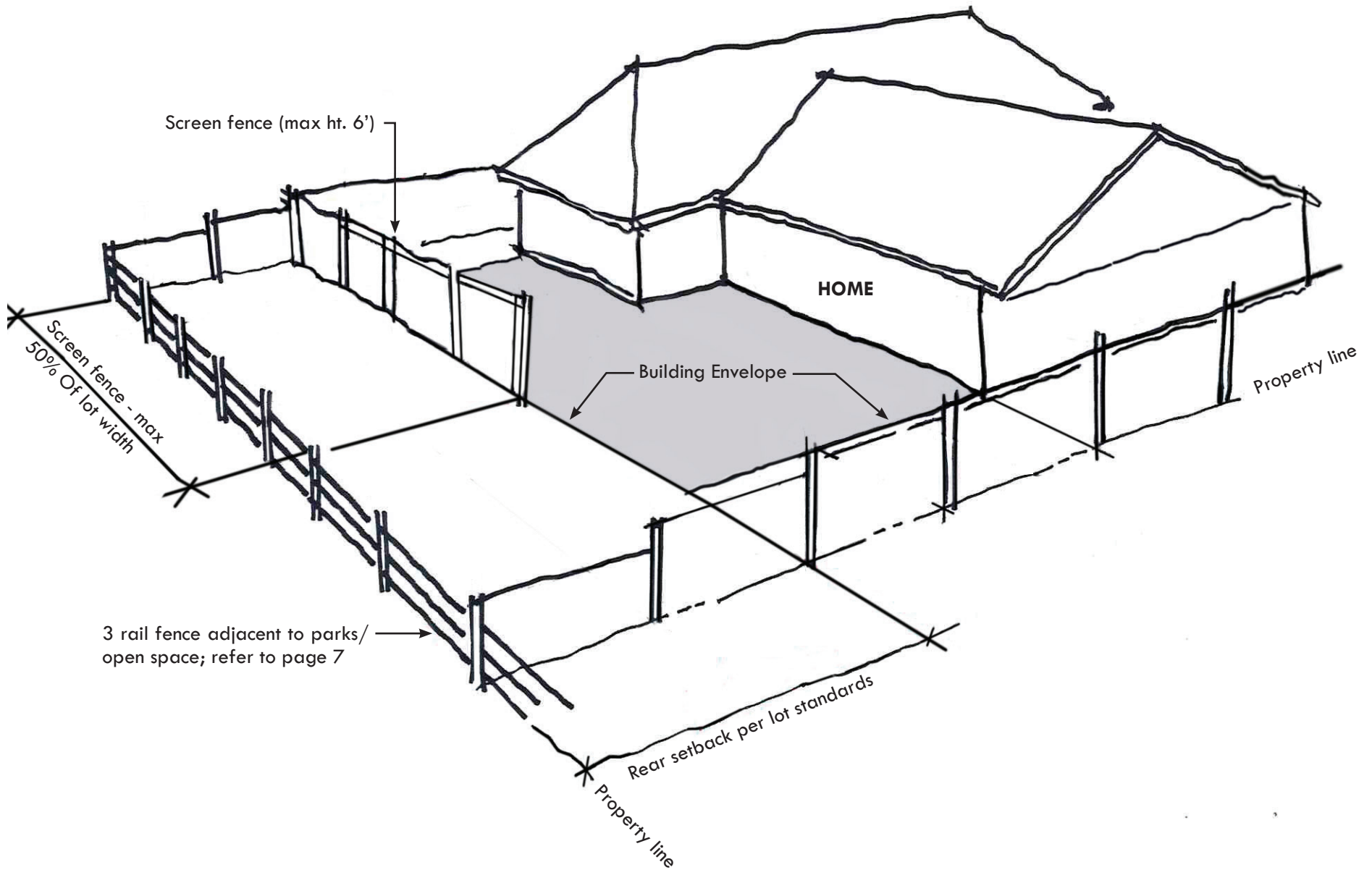
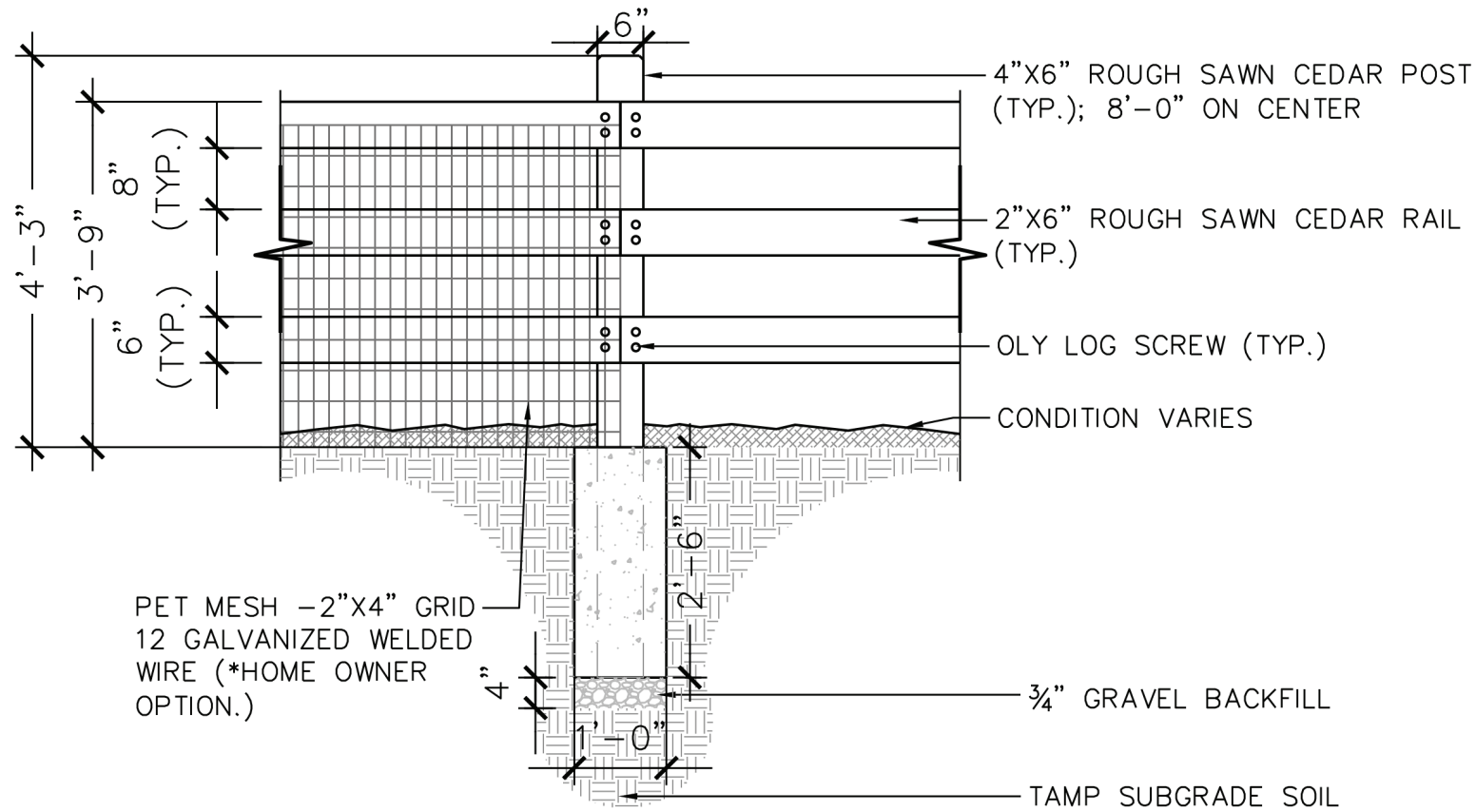

Exhibit B: Residential Fence Diagram Adjacent to Parks and Open Space

Park and Open Space Perimeter Fencing T1, T3 & T4 Transects



NOTES:

1. USE #1 GRADE CEDAR WOOD TREATED/STAINED TO A NATURAL CEDAR APPEARANCE.
2. SIDE OF FENCE SHOWN IN THIS DETAIL TO FACE HOUSES.



rural urban



T1 Rural Preserve

T3 Sub-Urban

T4 General Urban

T5 Urban Center

General Design Criteria:

- | | |
|-------------------|---|
| T1 Rural Preserve | Less formal, authentic materials |
| T3 Sub-Urban | Generally informal, durable, functional |
| T4 General Urban | Moderately formal, variety in design, relating to adjacent architecture |
| T5 Urban Center | More formal, creative use of materials/forms |

Examples of potential fencing materials.

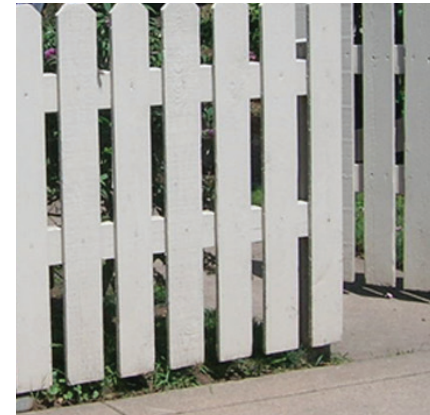

THREE SPRINGS - DURANGO, COLORADO

Mixed-use fencing examples

